

**ASI** | AQUASYNC  
INNOVATION  
YOUR SHIP'S GUARDIAN IN THE DIGITAL AGE



AQUASYNC INNOVATION(SINGAPORE) PTE. LTD.

Address: 8 Temasek Boulevard #11-01.Suntec city Tower 3, Singapore 038988

Online: E-mail 1: info@aquasync.sg E-mail 2: sales@aquasync.sg Website: www.aquasync.sg

# YOUR SHIP'S GUARDIAN IN THE DIGITAL AGE

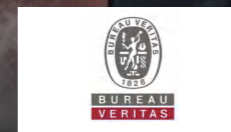

# Content.

YOUR SHIP'S GUARDIAN IN THE DIGITAL AGE

## AQUASYNC INNOVATION

Company Profile ----- P01

Global Presence & Headquarters Map ----- P02

ASI's Solutions for Ship ----- P03

**01** Integrated Gauging, Monitoring-Alarm and Controlling System ----- P05

Integrated Automation Control System Gplot ----- P07

Certificates (1.1 ~ 1.3 Compliant with IACS UR E27 standard) ----- P09

1.1 E/R Monitoring and Alarm System (Including Engineer Alarm System) ----- P11

1.2 Valve Remote Control and Level Gauging System ----- P13

1.3 Pressure, Temperature and Liquid Level Measurement Alarm System ----- P15

1.4 Energy Management System ----- P17

1.5 Natural Gas Fuel Control, Monitoring and Safety system ----- P19

1.6 Emergency shutdown Link ----- P21

**02** Informatization Integrated Solution ----- P23

**03** Intelligent Ship System ----- P33

**04** Ship-Fleet Management System ----- P47

**05** Ship Cybersecurity Solutions ----- P59

# Company Profile

AquaSync Innovation ( hereinafter referred to as ASI) provides a full package of solutions for comprehensive automation, intelligence, integrated ship-shore information and ship cyber security etc. in marine and offshore industries through cutting-edge technology, empowers the global maritime industry. Our advanced solutions ensure safe, reliable, efficient performance and promote the rapid sustainable development of the maritime industry's digitalization process.

ASI has obtained the **DNV-issued ISO 9001** Quality Management System, **ISO/IEC 27001** Information Security Management System, **ISO/IEC 20000-1** Information Technology Service Management System certificates, and the **ISO/IEC 17025** Marine Cyber Security Laboratory Test Capability Recognition.



Integrated Gauging Monitoring-Alarm and Controlling System



Informatization Integrated Solution



Intelligent ship system



Ship-Shore Fleet Management System



Ship Cybersecurity Solutions



Sensor Transmitters, Valves, Flow Meters and Other Underlying Hardware

# Global Presence & Headquarters Map

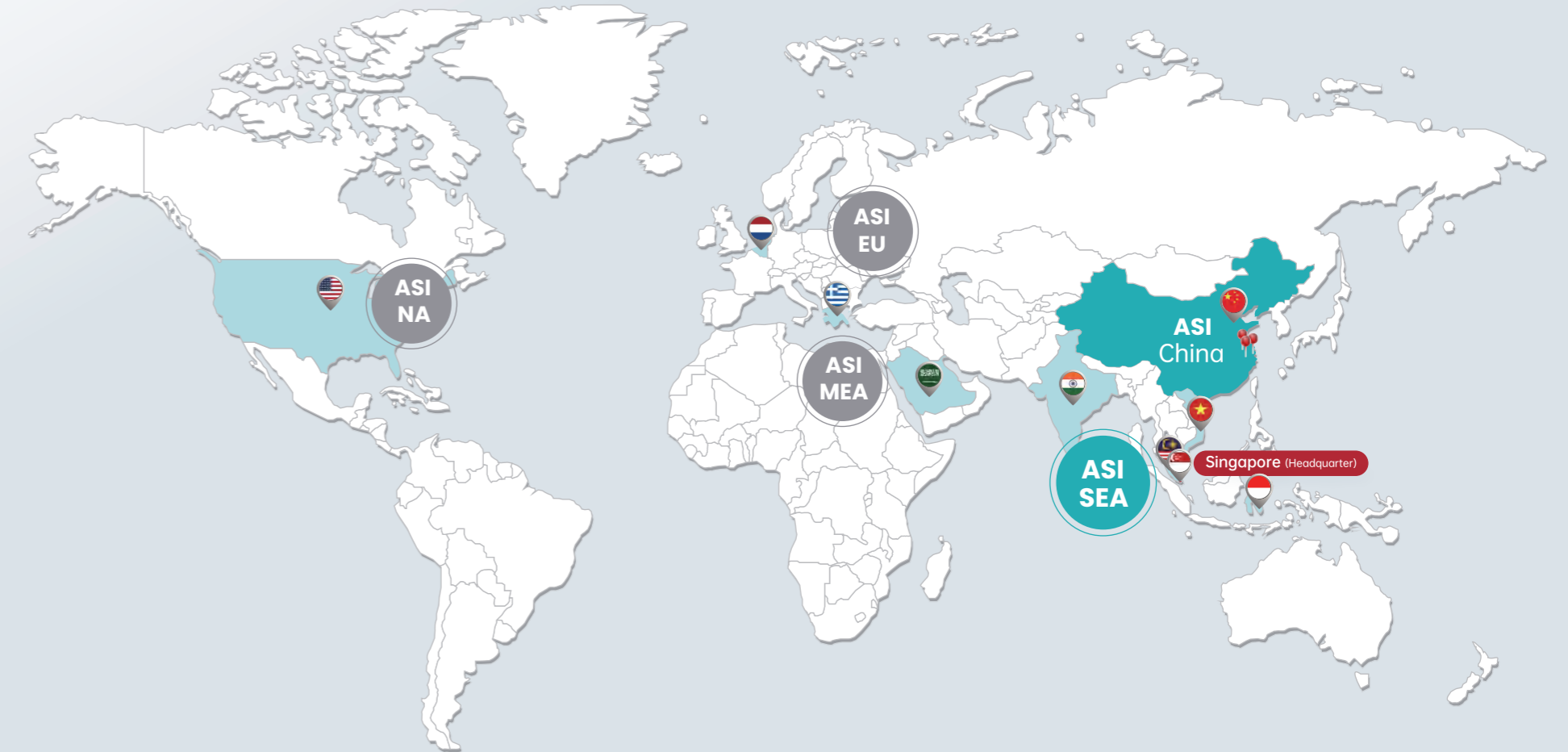

## ASI China

- Hangzhou, Zhejiang
- Wuxi, Jiangsu Province
- Shanghai

## ASI SEA

- Singapore
- India
- Malaysia

- Vietnam
- Indonesia

## ASI EU

- Netherlands
- Greece

## ASI MEA

- Saudi Arabia

## ASI NA

- America



# ASI'S SOLUTIONS FOR SHIP

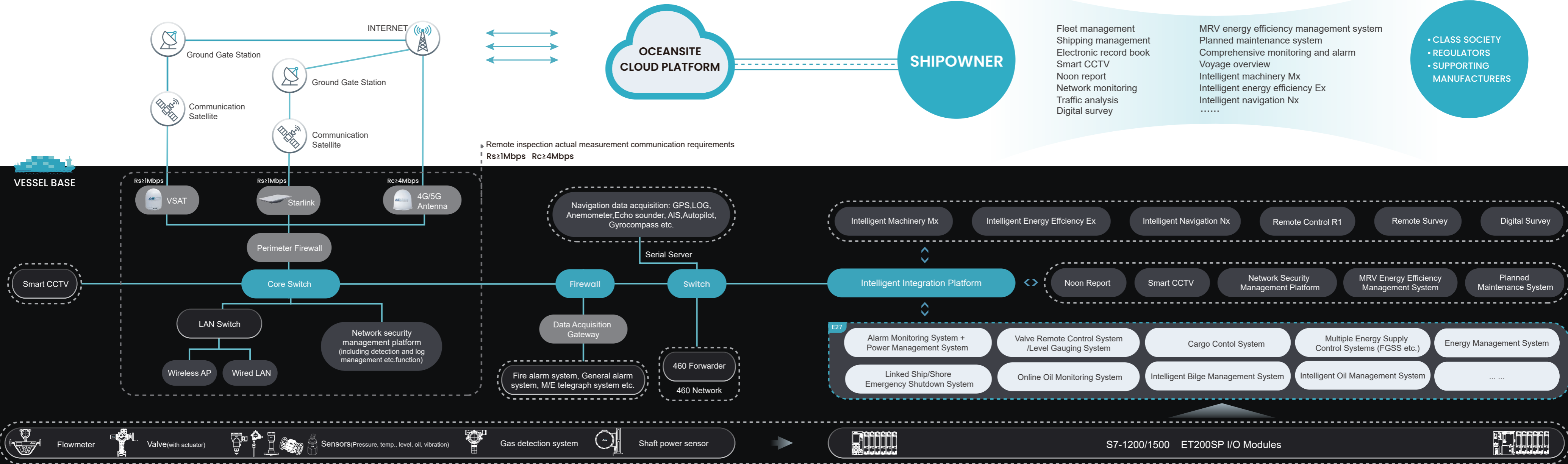

YOUR SHIP'S GUARDIAN IN THE DIGITAL AGE

# Integrated Gauging, Monitoring-Alarm and Controlling System

## Introduction to Ship Automation System: GCS-800

As part of ASI's marine automation solutions, the GCS-The system signal acquisition and control adopt the redundant looped network or A/B network structure as the control domain network. A/B network structure, dual network redundancy, as the operation domain network. The control domain network is physically isolated from the operation domain network. In the case of any single network disconnection failure and network equipment failure, the normal operation of the system is not affected at all. 800 is a ship integrated automation system built on Siemens . The system's modular design ensures high efficiency and reliability, making it adaptable to a wide range of vessel types and sizes, including bulk carriers, oil tankers, container ships, refrigerated ships, and other special-purpose vessels.

### GCS-800

PLC: S7-1200/1500 ET200SP I/O Modules LOGO! Series  
HMI: WinCC Monitoring Software

Control Domain Network (looped network & A/B Network)  
Operation Domain Network (A/B Network Dual Redundancy)  
*The control domain and operation domain networks are completely independent*

E/R Monitoring and Alarm System  
Valve Remote Control and Level Gauging System  
Pressure, Temperature and Liquid Level Measurement Alarm System

PLCs and Software  
Components

Network  
Architecture

Main Systems

# Integrated Automation Control System Gplot

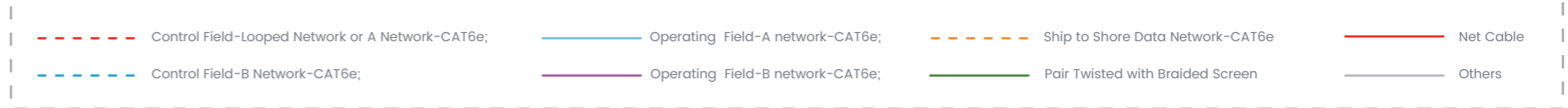
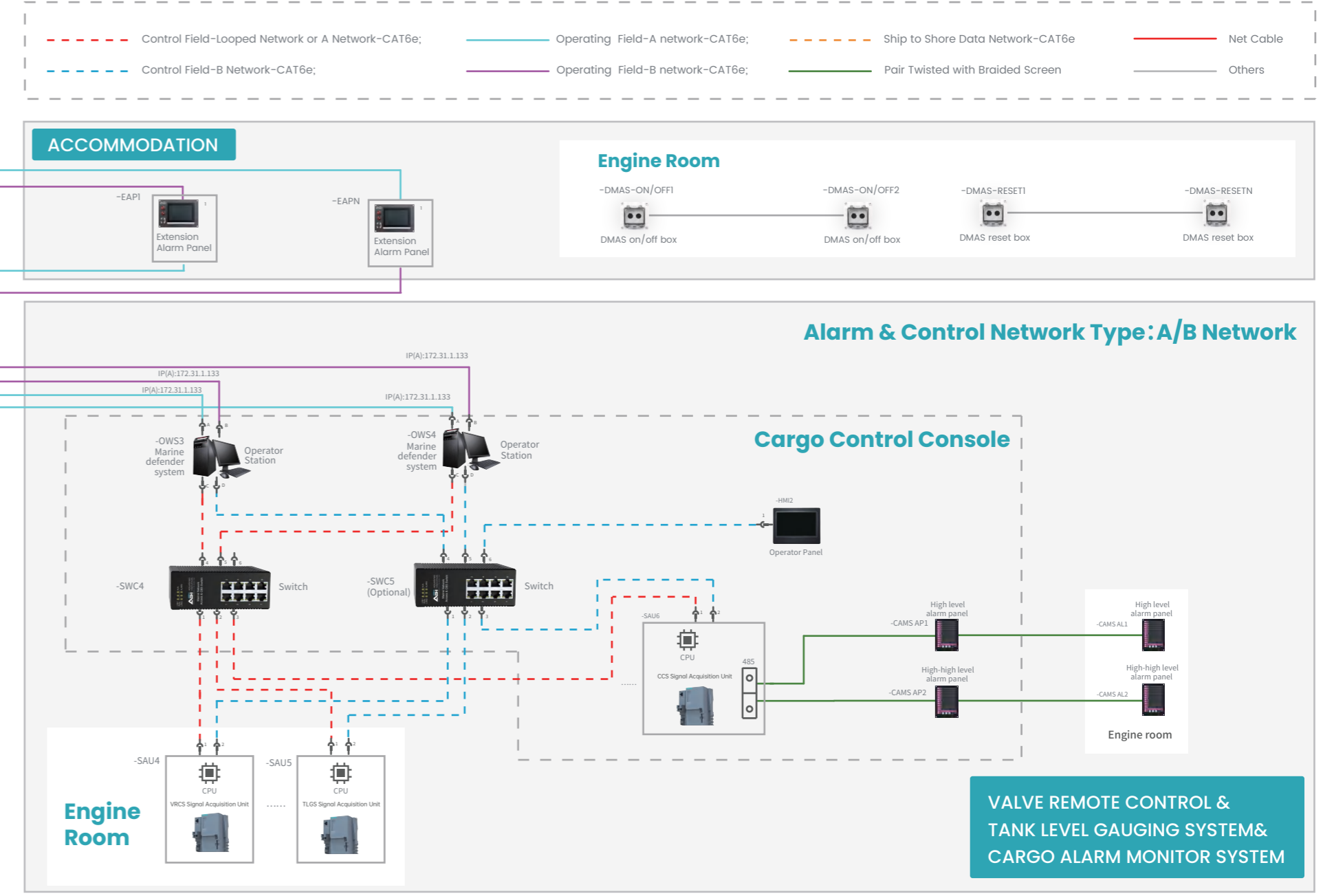
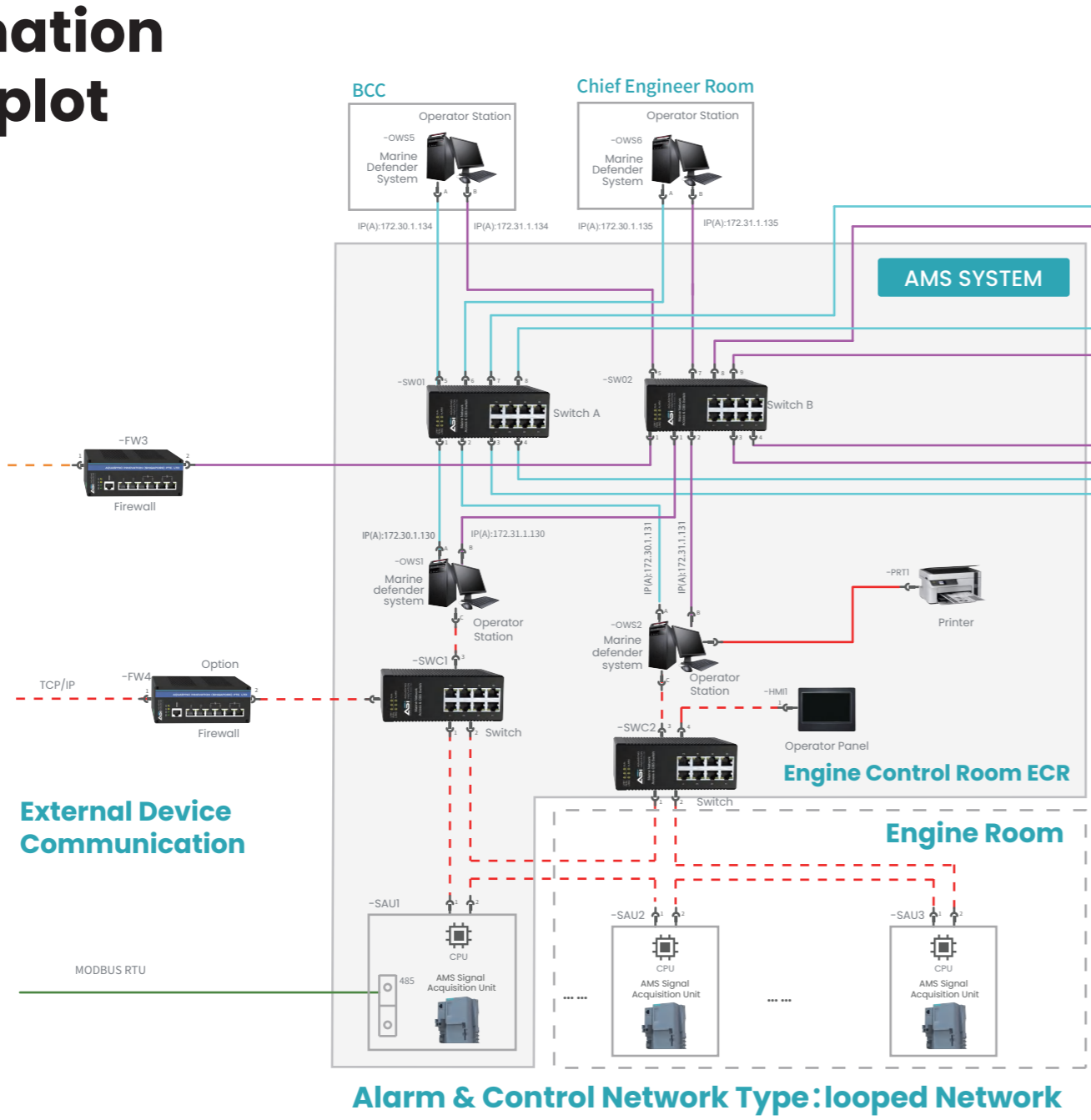
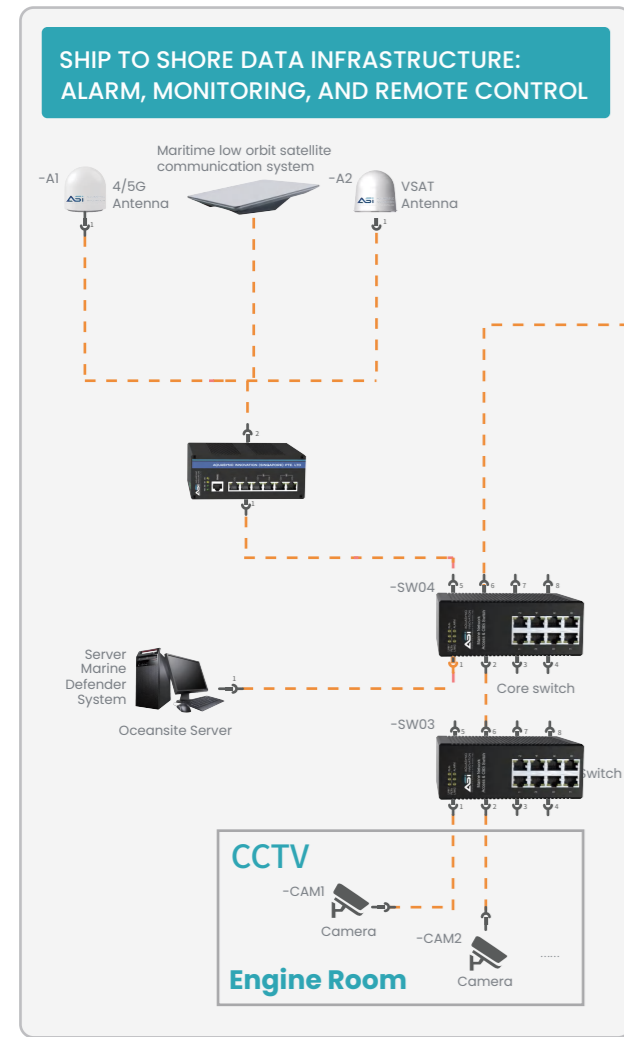

# Integrated Gauging, Monitoring-Alarm and Controlling System

## ABS Certificate of Product Design Assessment GCS800 (Endorsements: CyberSecurity)



# Integrated Gauging, Monitoring-Alarm and Controlling System

## LR Type Approval Certificate GCS800



# Integrated Gauging, Monitoring-Alarm and Controlling System

## CCS Certificate of Type Approval (Meet Cybersecurity Level SL2)

Integrated Gauging, Monitoring-Alarm and Controlling System includes AMS, VRCS & LGS and CMS, wwhich has obtained the world's first type approval certificate with cybersecurity (cybersecurity SL2 level) issued by CCS and supports real-time communication between ship and shore.



## Certificate Annex

- Pressure, Temperature and Liquid Level Measurement Alarm System
- Valve Remote Control and Level Gauging System
- Engine Room Monitoring and Alarm System and Engineer Alarm System
- Natural Gas Fuel Control, Monitoring and Safety System
- Energy Management System

证书编号 Certificate No.: ZC23P1800350 副页 Additional Page

产品说明/Product Description				
系统名称 System Name	压力、温度、液位测量报警系统 Pressure, temperature and liquid level measurement alarm system			
产品型号 Type	GC580-CM-C	GC580-CM-B	GC580-CM-F	GC580-CM-G
系统组成 System Composition	报警站(计算机、显示器)、以太网交换机、电源模块、控制柜、I/O模块、扩展连接模块、安全栅、报警音笛、HMI人机界面触摸屏、工作间(计算机、显示器)、产光报警、UPS、监控软件 Workstation (computer, monitor), control cabinet (Ethernet switch, power module, controller), I/O module, expansion connection module, barrier, alarm display board, HMI man-machine interface touch screen, alarm audible and visual alarm, UPS, monitoring software			
PLC型号/Model	中控Nagcon G3 smart	中控Supcon GS	西门子 Siemens S7-1200 S7-1500	西门子 Siemens ET200
电源 Power	220V AC, 24V DC			
网络安全等级 Cyber Security Class	SL2			
软件版本 Software Version	GC580-V1 90.00.00 VSCADA V2.20.00.00	WuCC V1.0 TIA Portal V19 Marine Defender System V2.20.00.00		
图纸批准号 Drawings Approval No.	ZJ24PFP0208			
认可标准 Approval Standard	(1) 中国船级社《船舶网络安全规范》(2024) 及其变更附录4 附录2、3 章 Chapter 2 and 3, Part Four of China Classification Society Rules for Classification of Sea-Going Steel Ships 2024 and its Change Notices (2) 中国船级社《船舶网络安全规范》(2024) 及其变更附录7 附录2 章 Chapter 2, Part Seven of China Classification Society Rules for Classification of Sea-Going Steel Ships 2024 and its Change Notices			

证书编号 Certificate No.: ZC23P1800350 副页 Additional Page

产品说明/Product Description				
系统名称 System Name	阀门遥控及液位报警系统 Valve Remote Control and Level Gauging System			
产品型号 Type	GC580-VRCL-G-B	GC580-VRCL-G-C	GC580-VRCL-G-D	GC580-VRCL-G-F
系统组成 System Composition	报警站(计算机、显示器)、以太网交换机、电源模块、控制柜、I/O模块、扩展连接模块、HMI人机界面触摸屏、安全栅、报警音笛、产光报警、UPS、监控软件 Workstation (computer, monitor), control cabinet (Ethernet switch, power module, controller), I/O module, expansion connection module, barrier, HMI man-machine interface touch screen, alarm audible and visual alarm, UPS, monitoring software			
PLC型号/Model	中控Nagcon G3 smart	中控Supcon GS	西门子 Siemens S7-1200 S7-1500	西门子 Siemens ET200
电源 Power	220V AC, 24V DC			
网络安全等级 Cyber Security Class	SL2			
软件版本 Software Version	GC580-V1 90.00.00 VSCADA V2.20.00.00	WuCC V1.0 TIA Portal V19 Marine Defender System V2.20.00.00		
图纸批准号 Drawings Approval No.	ZJ24PFP0208			
认可标准 Approval Standard	(1) 中国船级社《船舶网络安全规范》(2024) 及其变更附录4 附录2、3 章 Chapter 2 and 3, Part Four of China Classification Society Rules for Classification of Sea-Going Steel Ships 2024 and its Change Notices (2) 中国船级社《船舶网络安全规范》(2024) 及其变更附录7 附录2 章 Chapter 2, Part Seven of China Classification Society Rules for Classification of Sea-Going Steel Ships 2024 and its Change Notices			

证书编号 Certificate No.: ZC23P1800350 副页 Additional Page

产品说明/Product Description				
系统名称 System Name	机舱报警系统及其报警系统 Engine room monitoring and alarm system and Engineer alarm system			
产品型号 Type	GC580-AMS-C	GC580-AMS-D	GC580-AMS-E	GC580-AMS-F
系统组成 System Composition	报警站(计算机、显示器)、以太网交换机、电源模块、控制柜、信号采集柜(控制柜、电源模块、I/O模块、扩展连接模块、安全栅)、打印纸、延伸报警(SEP-A07 延伸报警)、舵机报警系统、HMI 人机界面触摸屏、UPS、监控软件 Workstation (computer, monitor), control cabinet (Ethernet switch, power module, controller), signal acquisition unit, controller, power module, I/O module, expansion connection module, barrier, printer, extended alarm system(SEP-A07 extension unit board), engineer alarm module, UPS, monitoring software			
PLC型号/Model	中控Nagcon G3 smart	中控Supcon GS	西门子 Siemens S7-1200 S7-1500	西门子 Siemens ET200
电源 Power	220V AC, 24V DC			
网络安全等级 Cyber Security Class	SL2			
软件版本 Software Version	GC580-V1 90.00.00	WuCC V1.0		
图纸批准号 Drawings Approval No.	ZJ24PFP0208			
认可标准 Approval Standard	(1) 中国船级社《船舶网络安全规范》(2024) 及其变更附录4 附录2、3 章 Chapter 2 and 3, Part Four of China Classification Society Rules for Classification of Sea-Going Steel Ships 2024 and its Change Notices (2) 中国船级社《船舶网络安全规范》(2024) 及其变更附录7 附录2 章 Chapter 2, Part Seven of China Classification Society Rules for Classification of Sea-Going Steel Ships 2024 and its Change Notices			

证书编号 Certificate No.: ZC23P1800350 副页 Additional Page

产品说明/Product Description				
系统名称 System Name	天然气燃料控制、监测和安全系统 Natural gas fuel control, monitoring and safety system			
产品型号 Type	GC580-FGCS-A	GC580-FGCS-B	GC580-FGCS-C	GC580-FGCS-D
系统组成 System Composition	报警站(计算机、显示器)、以太网交换机、电源模块、控制柜、I/O模块、通信模块、I/O模块、通信连接模块、扩展连接模块、报警音笛、产光报警、UPS、HMI 人机界面触摸屏、产光报警、产光报警、UPS、监控软件 Workstation (computer, monitor), Ethernet switch, UPS, HMI man-machine interface touch screen, audible and visual alarm, expansion connection module, barrier, alarm audible and visual alarm, UPS, HMI man-machine interface touch screen, alarm audible and visual alarm, UPS, monitoring software			
PLC型号/Model	中控Nagcon G3 smart	中控Supcon GS	西门子 Siemens S7-1200 S7-1500	西门子 Siemens ET200
电源 Power	220V AC, 24V DC			
网络安全等级 Cyber Security Class	SL2			
软件版本 Software Version	GC580-V1 90.00.00 VSCADA V2.20.00.00	WuCC V1.0 TIA Portal V19 Marine Defender System V2.20.00.00		
图纸批准号 Drawings Approval No.	ZJ24PFP0208			
认可标准 Approval Standard	(1) 中国船级社《船舶网络安全规范》(2024) 及其变更附录4 附录2、3 章 Chapter 2 and 3, Part Four of China Classification Society Rules for Classification of Sea-Going Steel Ships 2024 and its Change Notices (2) 中国船级社《船舶网络安全规范》(2024) 及其变更附录7 附录2 章 Chapter 2, Part Seven of China Classification Society Rules for Classification of Sea-Going Steel Ships 2024 and its Change Notices (3) 中国船级社《船舶网络安全规范》(2024) 第1、2、3 章 Chapter 1, 2, 3 of China Classification Society Guidelines for Ship Cyber Security (2024) (4) IACS UR E27 (Rev 1) 船机系统和设备网络附件 IACS UR E27 (Rev 1) Cyber resilience of on-board systems and equipment			

证书编号 Certificate No.: ZC23P1800350 副页 Additional Page

产品说明/Product Description				
系统名称 System Name	机舱报警系统及其报警系统 Engine room monitoring and alarm system and Engineer alarm system			
产品型号 Type	GC580-AMS-C	GC580-AMS-D	GC580-AMS-E	GC580-AMS-F
系统组成 System Composition	报警站(计算机、显示器)、以太网交换机、电源模块、控制柜、信号采集柜(控制柜、电源模块、I/O模块、扩展连接模块、安全栅)、打印纸、延伸报警(SEP-A07 延伸报警)、舵机报警系统、HMI 人机界面触摸屏、UPS、监控软件 Workstation (computer, monitor), control cabinet (Ethernet switch, power module, controller), signal acquisition unit, controller, power module, I/O module, expansion connection module, barrier, printer, extended alarm system(SEP-A07 extension unit board), engineer alarm module, UPS, monitoring software			
PLC型号/Model	中控Nagcon G3 smart	中控Supcon GS	西门子 Siemens S7-1200 S7-1500	西门子 Siemens ET200
电源 Power	220V AC, 24V DC			
网络安全等级 Cyber Security Class	SL2			
软件版本 Software Version	GC580-V1 90.00.00	WuCC V1.0		
图纸批准号 Drawings Approval No.	ZJ24PFP0208			
认可标准 Approval Standard	(1) 中国船级社《船舶网络安全规范》(2024) 及其变更附录4 附录2、3 章 Chapter 2 and 3, Part Four of China Classification Society Rules for Classification of Sea-Going Steel Ships 2024 and its Change Notices (2) 中国船级社《船舶网络安全规范》(2024) 及其变更附录7 附录2 章 Chapter 2, Part Seven of China Classification Society Rules for Classification of Sea-Going Steel Ships 2024 and its Change Notices (3) 中国船级社《船舶网络安全规范》(2024) 第1、2、3 章 Chapter 1, 2, 3 of China Classification Society Guidelines for Ship Cyber Security (2024) (4) IACS UR E27 (Rev 1) 船机系统和设备网络附件 IACS UR E27 (Rev 1) Cyber resilience of on-board systems and equipment			

证书编号 Certificate No.: ZC23P1800350 副页 Additional Page

产品说明/Product Description				
系统名称 System Name	天然气燃料控制、监测和安全系统 Natural gas fuel control, monitoring and safety system			
产品型号 Type	GC580-FGCS-A	GC580-FGCS-B	GC580-FGCS-C	GC580-FGCS-D
系统组成 System Composition	报警站(计算机、显示器)、以太网交换机、电源模块、控制柜、I/O模块、通信模块、I/O模块、通信连接模块、扩展连接模块、报警音笛、产光报警、UPS、HMI 人机界面触摸屏、产光报警、产光报警、UPS、监控软件 Workstation (computer, monitor), Ethernet switch, UPS, HMI man-machine interface touch screen, audible and visual alarm, expansion connection module, barrier, alarm audible and visual alarm, UPS, HMI man-machine interface touch screen, alarm audible and visual alarm, UPS, monitoring software			
PLC型号/Model	中控Nagcon G3 smart	中控Supcon GS	西门子 Siemens S7-1200 S7-1500	西门子 Siemens ET200
电源 Power	220V AC, 24V DC			
网络安全等级 Cyber Security Class	SL2			
软件版本 Software Version	GC580-V1 90.00.00 VSCADA V2.20.00.00	WuCC V1.0 TIA Portal V19 Marine Defender System V2.20.00.00		
图纸批准号 Drawings Approval No.	ZJ24PFP0208			
认可标准 Approval Standard	(1) 中国船级社《船舶网络安全规范》(2024) 及其变更附录4 附录2、3 章 Chapter 2 and 3, Part Four of China Classification Society Rules for Classification of Sea-Going Steel Ships 2024 and its Change Notices (2) 中国船级社《船舶网络安全规范》(2024) 及其变更附录7 附录2 章 Chapter 2, Part Seven of China Classification Society Rules for Classification of Sea-Going Steel Ships 2024 and its Change Notices (3) 中国船级社《船舶网络安全规范》(2024) 第1、2、3 章 Chapter 1, 2, 3 of China Classification Society Guidelines for Ship Cyber Security (2024) (4) IACS UR E27 (Rev 1) 船机系统和设备网络附件 IACS UR E27 (Rev 1) Cyber resilience of on-board systems and equipment			

# Integrated Gauging, Monitoring-Alarm and Controlling System

## KR Certificate of Type Approval (Meet UR E27 Cybersecurity)



## RINA Certificate of Type Approval

### RINA Certificate of Type Approval (Meet UR Rules for the Classification of Ship)

### RINA Certificate of Type Approval (Meet UR IACS UR E27 Rev.1 Cyber Resilience of On-board systems and equipment)

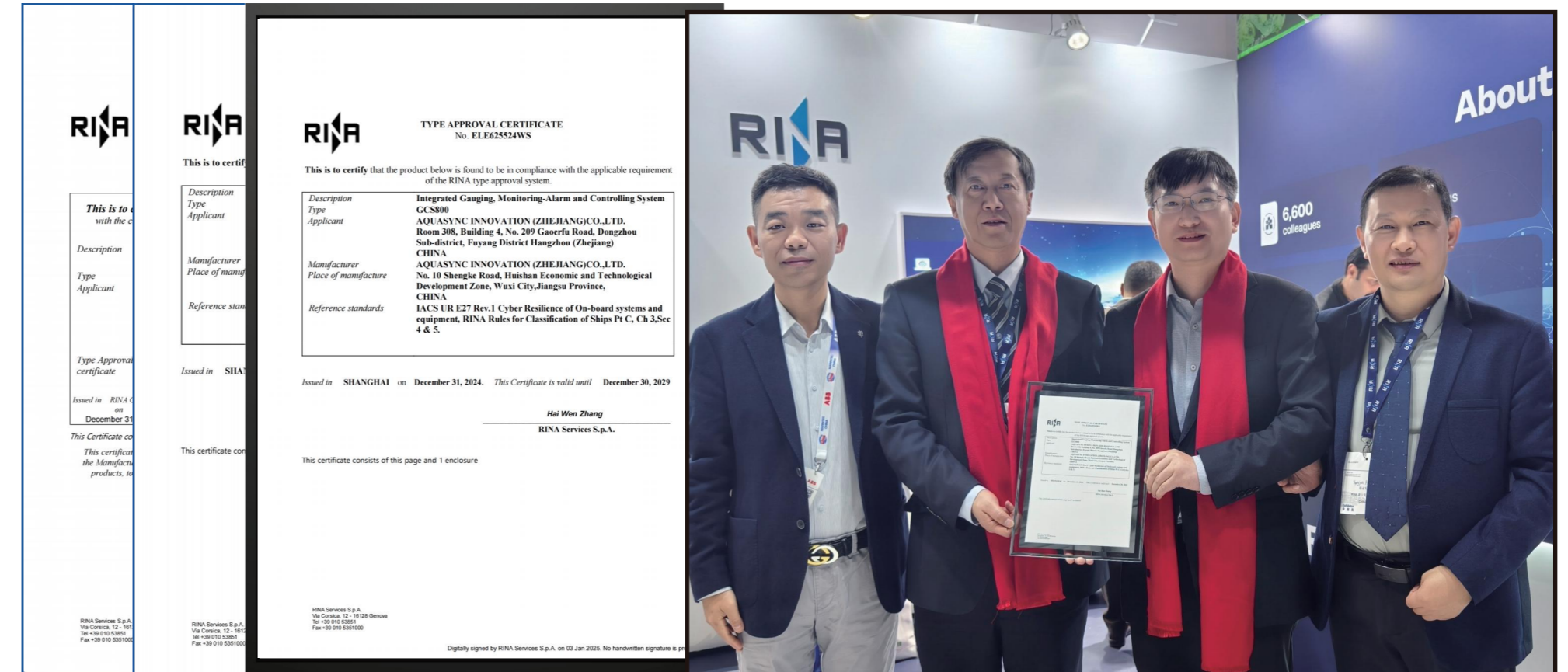

# INTEGRATED GAUGING, MONITORING-ALARM AND CONTROLLING SYSTEM

## 1.1 E/R Monitoring and Alarm System (Including Engineer Alarm System)

### System Features

- Decentralized Signal Acquisition & Centralized Monitoring.
- Safety & Alarm Management Integration.
- Comprehensive system redundancy, including network, controller hot standby, and I/O card redundancy.
- Unmanned Engine Room Compliance & Functionality.
- Extension Alarm System.
- Engineer Alarm System & Engineer Call/On Duty.
- Synchronize the Clock.
- Fan and Motor Control.
- Compliant with IACS UR E27 cybersecurity requirements.



# INTEGRATED GAUGING, MONITORING-ALARM AND CONTROLLING SYSTEM

## 1.2 Valve Remote Control and Level Gauging System

### System Features

- Efficient remote operation of valves.
- User-friendly interface for simple and intuitive interaction.
- Real-time monitoring of valve status at all times.
- Redundant system design to ensure safe and stable performance.
- Built-in self-diagnostics for quick fault detection and troubleshooting.
- Simple system structure for easy installation and maintenance.
- Compatible with various types of valves and piping systems.
- Timeout alarm triggered upon detection of abnormal valve behavior.
- Multi-level user access control for enhanced security.
- Redundant architecture to improve system reliability.
- Support for multiple communication protocols and interfaces.
- Explosion-proof design for operation in hazardous environments.
- Compliant with IACS UR E27 cybersecurity standards.

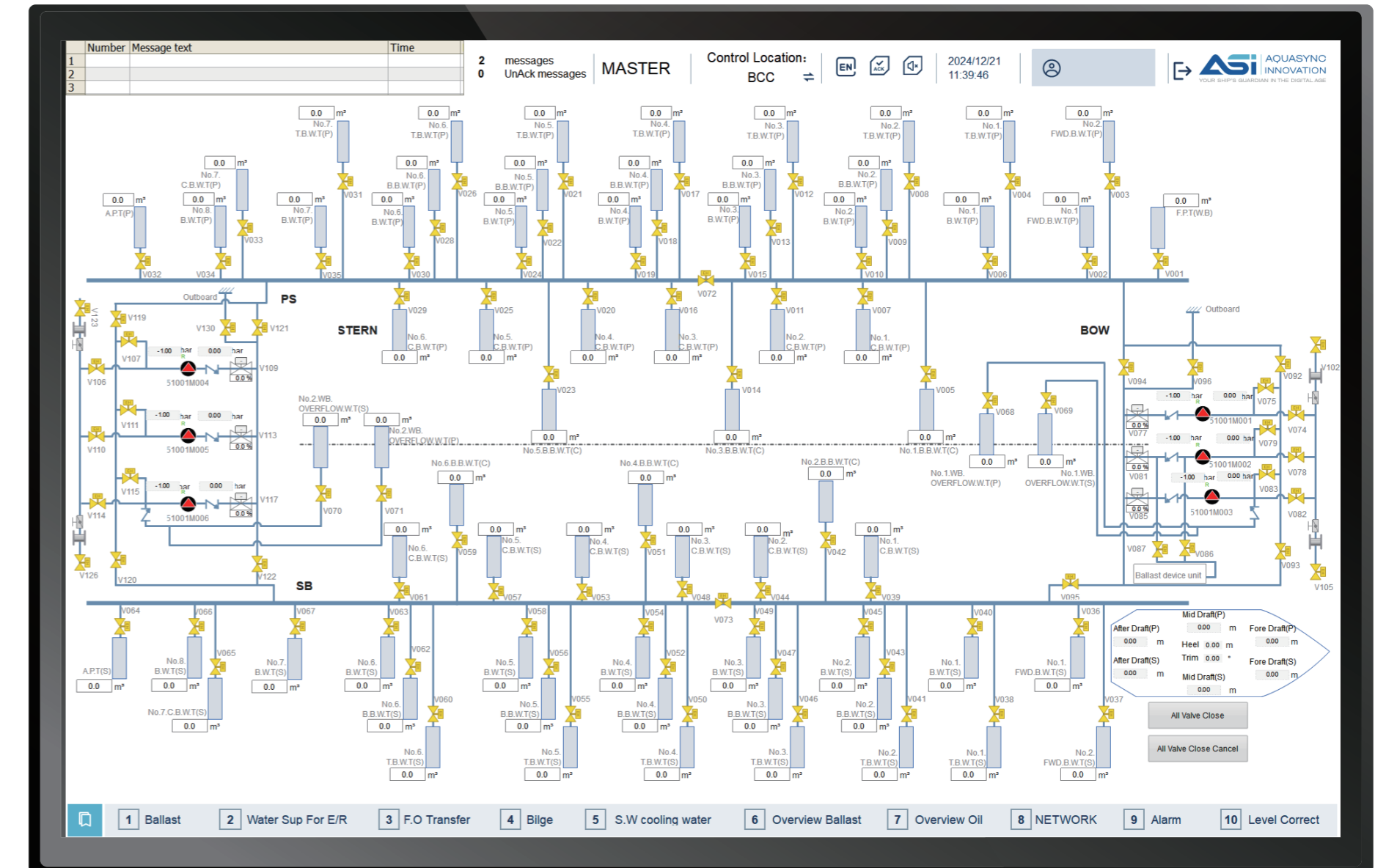

# INTEGRATED GAUGING, MONITORING-ALARM AND CONTROLLING SYSTEM

## 1.3 Pressure, Temperature and Liquid Level Measurement Alarm System

### System Features

- Acquisition, display, and alarm functions for pressure, temperature, and liquid level signals.
- Tank volume calculation, correction, and display functions.
- Self-diagnosis and alarm functions for sensor faults, loop faults, module faults, and communication faults.
- External communication support via TCP/IP and RS485.
- Compliant with IACS UR E27 cybersecurity requirements.

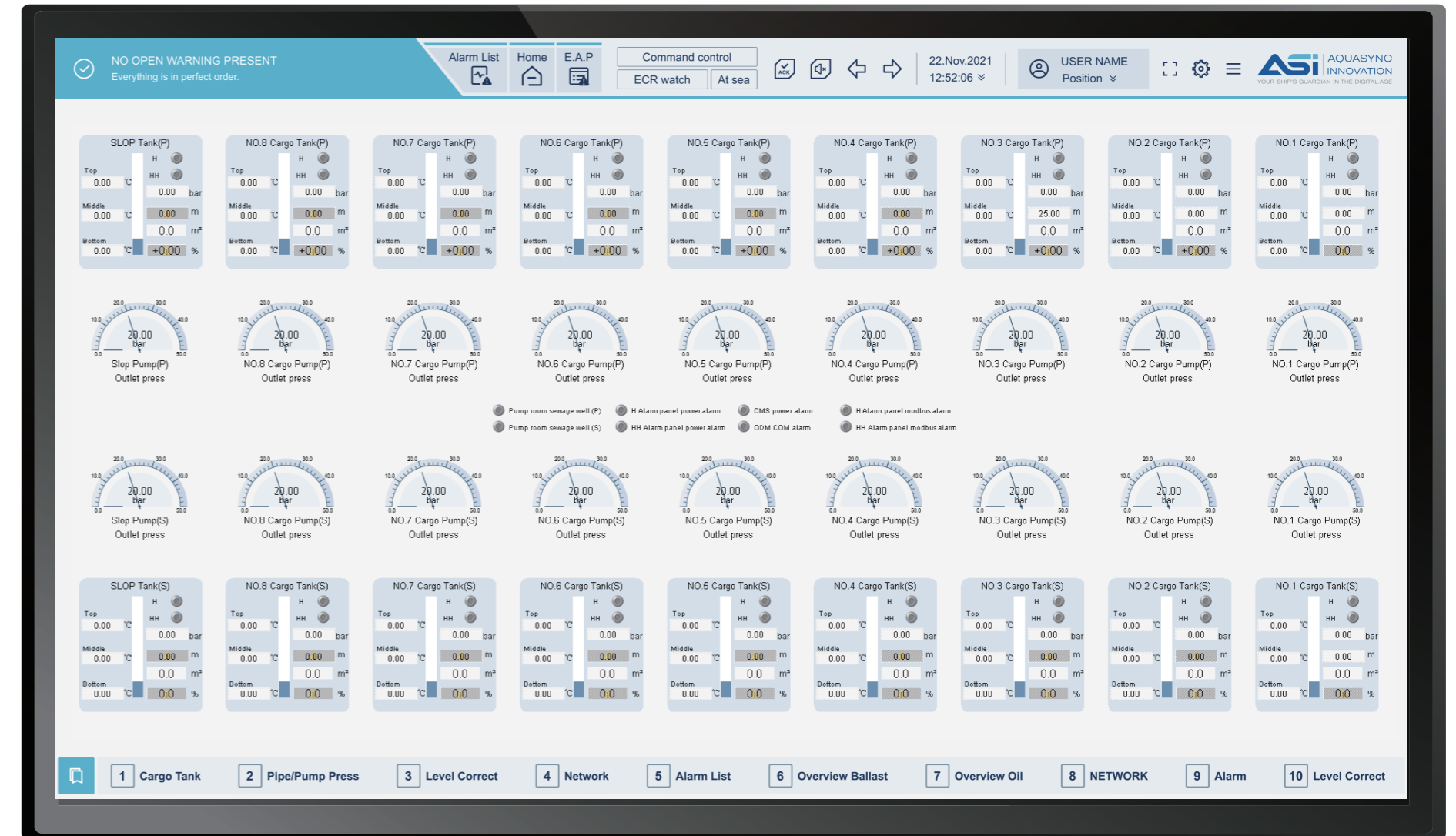

# INTEGRATED GAUGING, MONITORING-ALARM AND CONTROLLING SYSTEM

## 1.4 Energy Management System

### System Features

- Charge and discharge power equalization function.
- Peak shaving function.
- Heavy consumer request function.
- Black-out recovery function.
- Priority trip function.
- Sequential start function for critical loads.
- Support third party communication.
- Support remote monitoring.
- Compliant with IACS UR E27 cybersecurity requirements.



# INTEGRATED GAUGING, MONITORING-ALARM AND CONTROLLING SYSTEM

## 1.5 Natural Gas Fuel Control, Monitoring and Safety System

### System Features

- Process control for pump, fan, compressor, valve.
- Fire and gas detection.
- Process shutdown and emergency shutdown.
- Audible and visual alarm.
- Support third party communication.
- Support remote monitoring.
- Compliant with IACS UR E27 cybersecurity requirements.

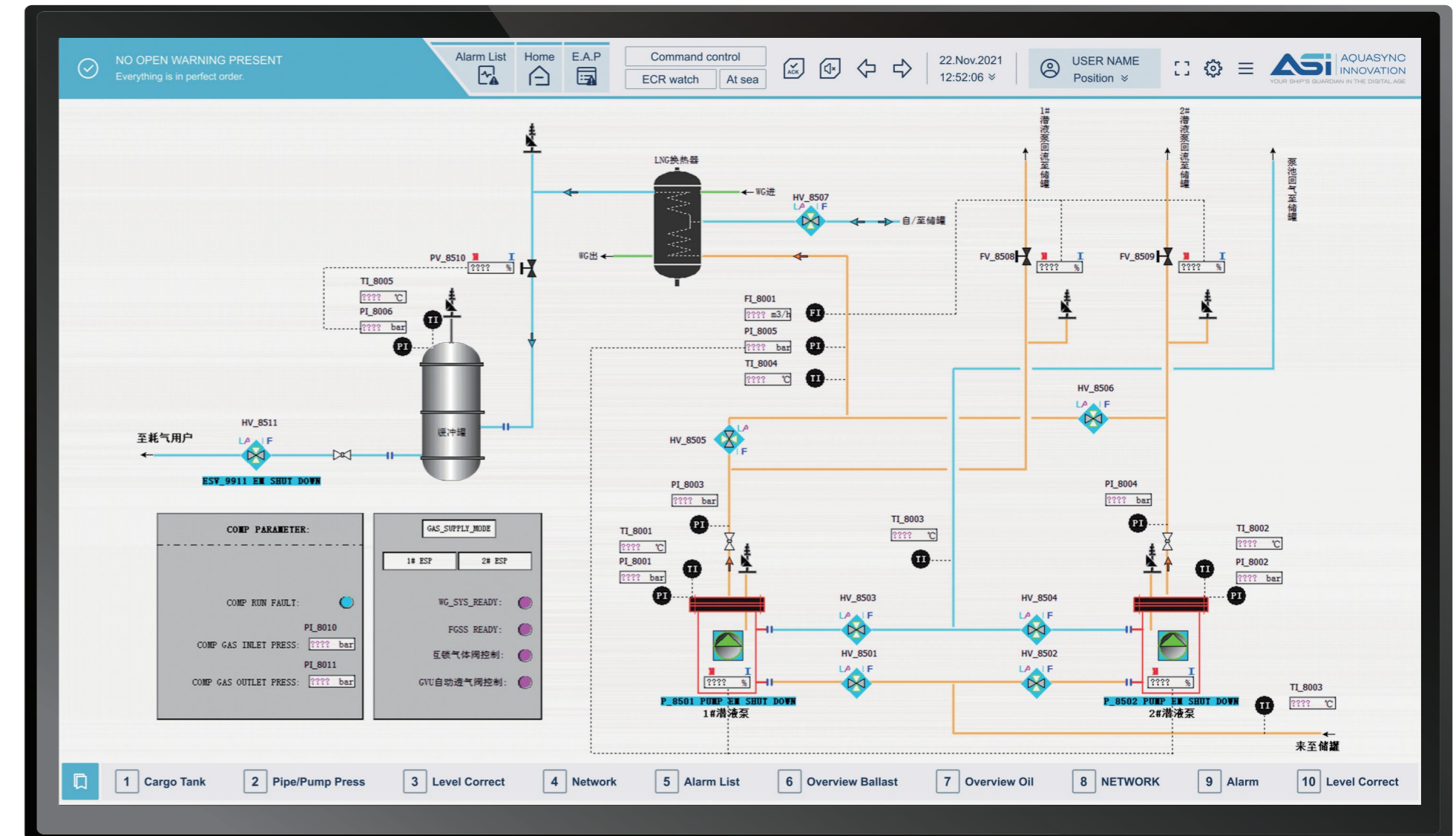

# INTEGRATED GAUGING, MONITORING-ALARM AND CONTROLLING SYSTEM

## 1.6 Emergency shutdown Link

### System Features

- Designed for ship-to-ship, ship-to-shore, and shore-to-ship applications.
- Suitable for liquid chemical and oil transfer operations.
- Provides galvanic isolation between ship and shore.
- Junction boxes on port and starboard manifolds include ESD buttons and 5-pin sockets for shore ESD or portable pendant connections.
- Includes 'First-Up' indication to identify the ESD activation point.
- Approved for use in Ex de IIC hazardous areas.
- Complies with current SIGTTO guidelines for liquid transfer.
- Meets OCIMF and CDI requirements for oil and chemical transfer operations.

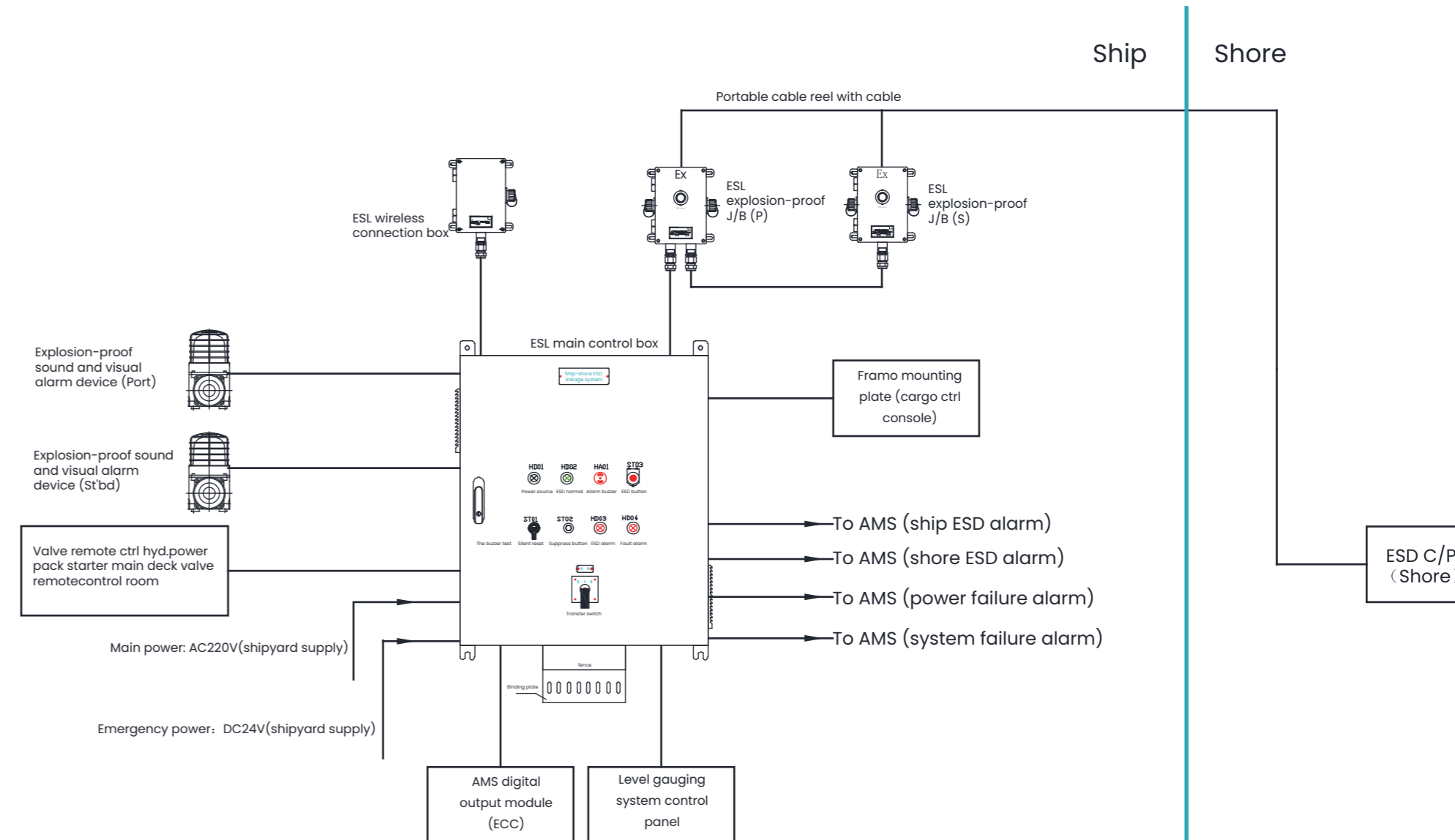

YOUR SHIP'S GUARDIAN IN THE DIGITAL AGE

# Informatization Integrated Solution

## 2.1 Network Information Integration System Gplot

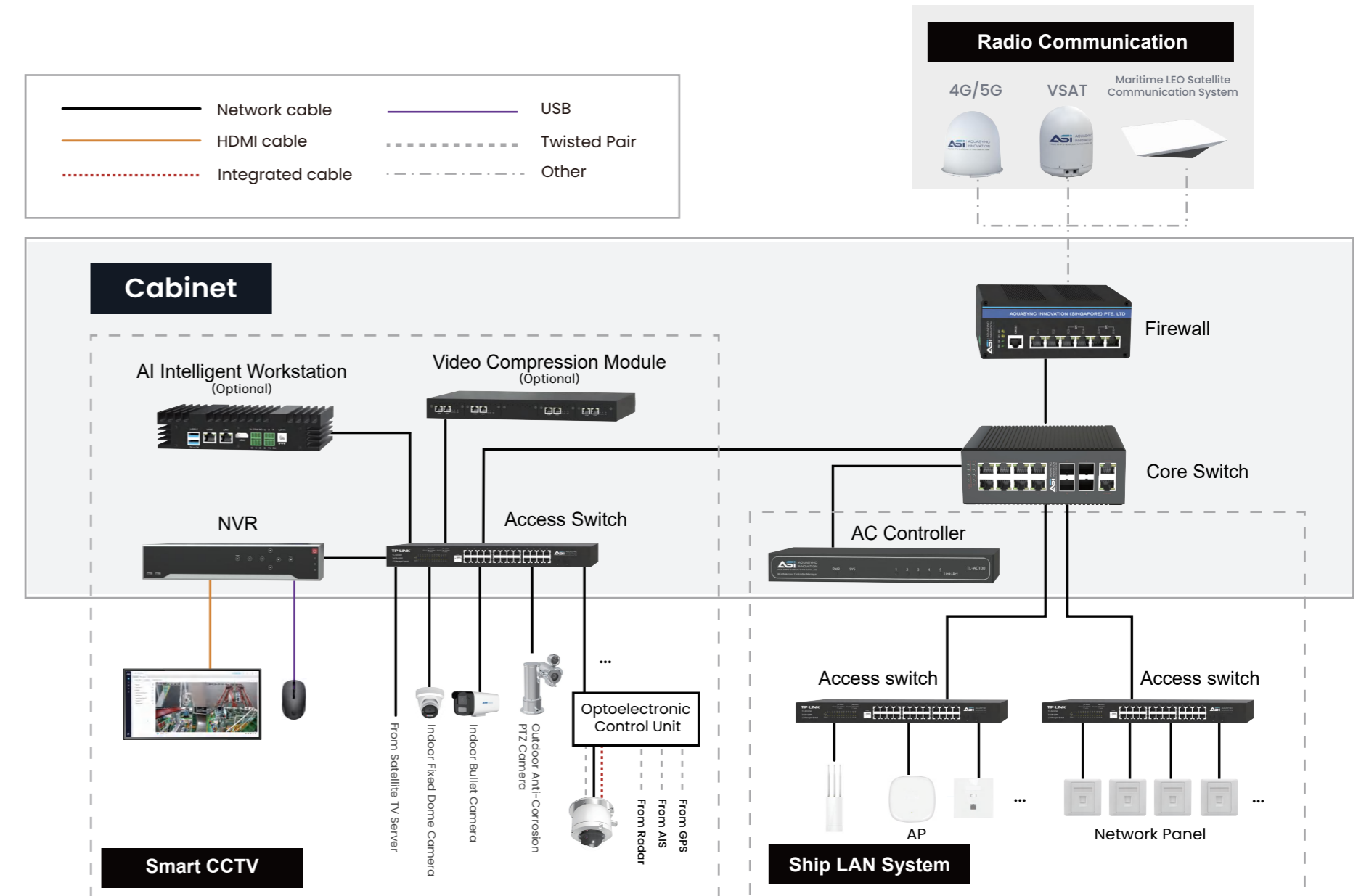



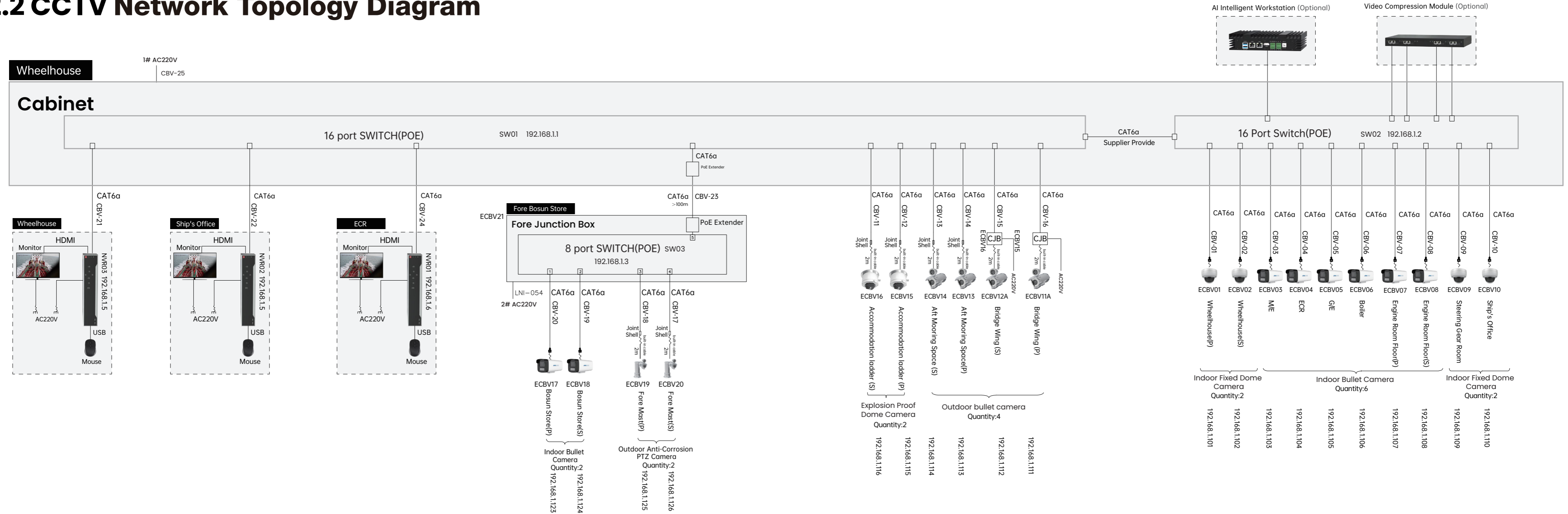

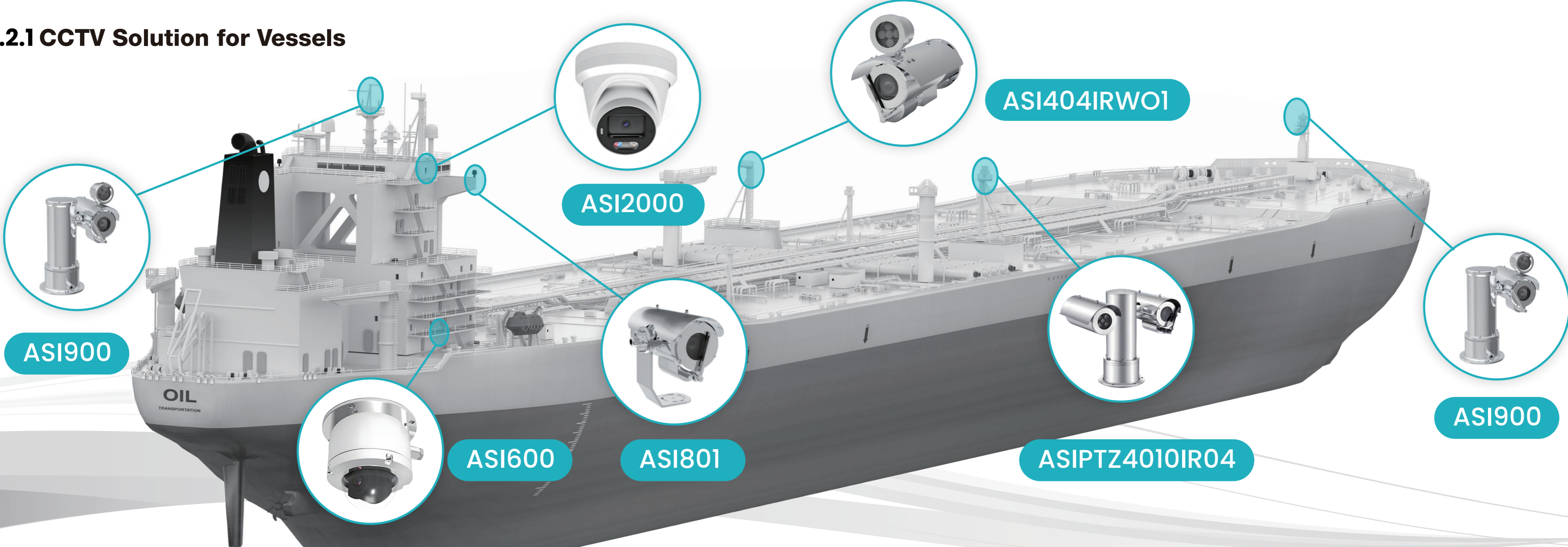

# 2.2 CCTV Network Topology Diagram













### 2.2.1 CCTV Solution for Vessels



## 2.2.2 CCTV System

Name	Outdoor Anti-Corrosion PTZ Camera	Outdoor Dome Camera	Outdoor Bullet Camera	Indoor Bullet Camera	Indoor Fixed Dome Camera	Outdoor Anti-Corrosion PTZ Camera	Outdoor Dome Camera	Outdoor Bullet Camera
Model	ASI-2DY7430I-CWX	ASI-2DF8C432MX-AY	ASI-2XC6646-IZHRSY	ASI-2CD2245CV6-L	ASI-2CD2345CV4-I	ASI900	ASI600	ASI-VL404IRW01
Product Image								
Pixel	4MP	4MP	4MP	4MP	4MP	4MP	4MP	4MP
Protection Grade	IP68	IP67	IP68	IP66	IP67	IP68	IP67	IP68
Focal Length	Zoom available, 32x	Zoom available, 32x	Zoom available, 4x	Fixed focus	Fixed focus	Zoom available, 33x	Zoom available, 5x	Zoom available, 4x
Chinese Interface	√	√	√	√	√	√	√	/
English Interface	/	/	/	/	/	√	√	√
DC12V Power Supply	/	/	/	/	/	/	/	/
AC/DC24V Power Supply	/	√	/	/	/	/	/	/
AC100V-240V Power Supply	√	/	/	/	/	√	/	/
POE Power supply	/	/	√	√	√	/	√	√
Heating	√	√	√	/	/	√	/	√
Infrared	150m	500m	60m	30m	30m	150m	40m	100m
Wiper	√	√	√	/	/	√	/	√
Explosion-proof	/	/	/	/	/	/	/	/
Suggested Installation Location	Compass deck, mast, deck, bow and stern monitoring	Left and right wings, port and starboard sides, front and rear mooring areas, gangway passage	Left and right wings, port and starboard sides, front and rear mooring areas, gangway passage	Engine Room	Cab, central control room, indoor rooms and corridors	Compass deck, mast, deck bow and stern monitoring	Left and right wings, port and starboard sides, front and rear mooring areas, gangway passage	Left and right wings, port and starboard sides, front and rear mooring areas, gangway passage

Outdoor Bullet Camera	Outdoor Bullet Camera	Outdoor Bullet Camera	Outdoor Bullet Camera	Indoor Fixed Dome Camera	Indoor Fixed Dome Camera	Explosion Proof Dome Camera	Explosion Proof PTZ Camera	Explosion Proof Bullet Camera	Explosion Proof Bullet Camera
ASI-VL432IRW01	ASI801	ASI-FL404IR02	ASI300	ASI2000	ASI-2CD1143G0-I	EX-ASIPTZ4010IR04N	EX-ASIPTZ4033IRW01	EX-ASI404IRW01	EX-ASI404IR02
									
4MP	4MP	4MP	4MP	4MP	4MP	4MP	4MP	4MP	4MP
IP68	IP68	IP68	IP68	IP66	IP67	IP67	IP68	IP68	IP68
Zoom available, 32x	Zoom available, 18x	Fixed focus	Fixed focus	Fixed focus	Fixed focus	Zoom available, 5x	Zoom available, 33x	Zoom available, 4x	Fixed focus
/	√	/	√	/	/	√	√	/	/
√	√	√	√	√	√	√	√	√	√
/	√	/	/	/	/	/	/	/	/
/	/	/	/	/	/	/	/	/	/
√	/	/	/	/	/	/	√	/	/
√	√	/	/	/	/	/	√	√	/
200m	/	30m	15m	30m	30m	40m	150m	100m	30m
√	√	/	/	/	/	/	√	√	/
/	/	/	/	/	/	ATEX:II 2G Ex db IIC T6 Gb	ATEX:II 2G Ex db IIC T6 Gb	ATEX:II 2G Ex db IIC T6 Gb	ATEX:II 2G Ex db IIC T6 Gb
Left and right wings, port and starboard sides, front and rear mooring areas, gangway passage	Left and right wings, port and starboard sides, front and rear mooring areas, gangway passage	Left and right wings, port and starboard sides, front and rear mooring areas, gangway passage	Left and right wings, port and starboard sides, front and rear mooring areas, gangway passage	Cab, central control room, indoor rooms and corridors	Cab, central control room, indoor rooms and corridors	Left and right wings, port and starboard sides, front and rear mooring areas, gangway passage	Compass deck, mast, deck bow and stern monitoring	Left and right wings, port and starboard sides, front and rear mooring areas, gangway passage	Left and right wings, port and starboard sides, front and rear mooring areas, gangway passage

## 2.3 Smart CCTV Technological Policies Reference

Requirement / Standard	India DGS MSN 02/2025	China MSA Technical Guide 1.0
Effective Date	Existing: 12 Feb 2028 Newly Registered Ships: 3 year from registration date	Mar. 2025
Applicability	Indian flagged and SPL Vessels	Domestic Oil /Chemical Tankers, Gas Carriers and Passenger Ships
Minimum Resolution $\geq 1080p$ / $\geq 2MP$	✓	✓
Min. Frame Rate $\geq 30FPS$ / $\geq 15FPS$	✓	✓
Ingress Protection (IP66 In-door & IP68 Outdoor)	✓	
Marine-grade Certification	✓	
AI Anomaly Detection (Fatigue, Fire, PPE, etc.)	✓ (Recommended)	✓ (Mandatory)
Edge AI Device $\geq 6TOPS$		✓
Real-time Voice Alarm		✓
Min. Local Storage (14 days / 30 days)	✓ (14 days)	✓ (30 days)
Remote Viewing & Alerts	✓	✓
Cybersecurity Compliance	✓	
IEC 62676	✓	
MLPS 2.0		✓

Our smart CCTV system exceeds the safety and surveillance requirements outlined in India's DGS MSN 02 of 2025 and fully complies with the technical standards mandated by China's MLPS Level 2 and MSA Technical Guide 1.0.

## 2.4 Network Information Cabinet

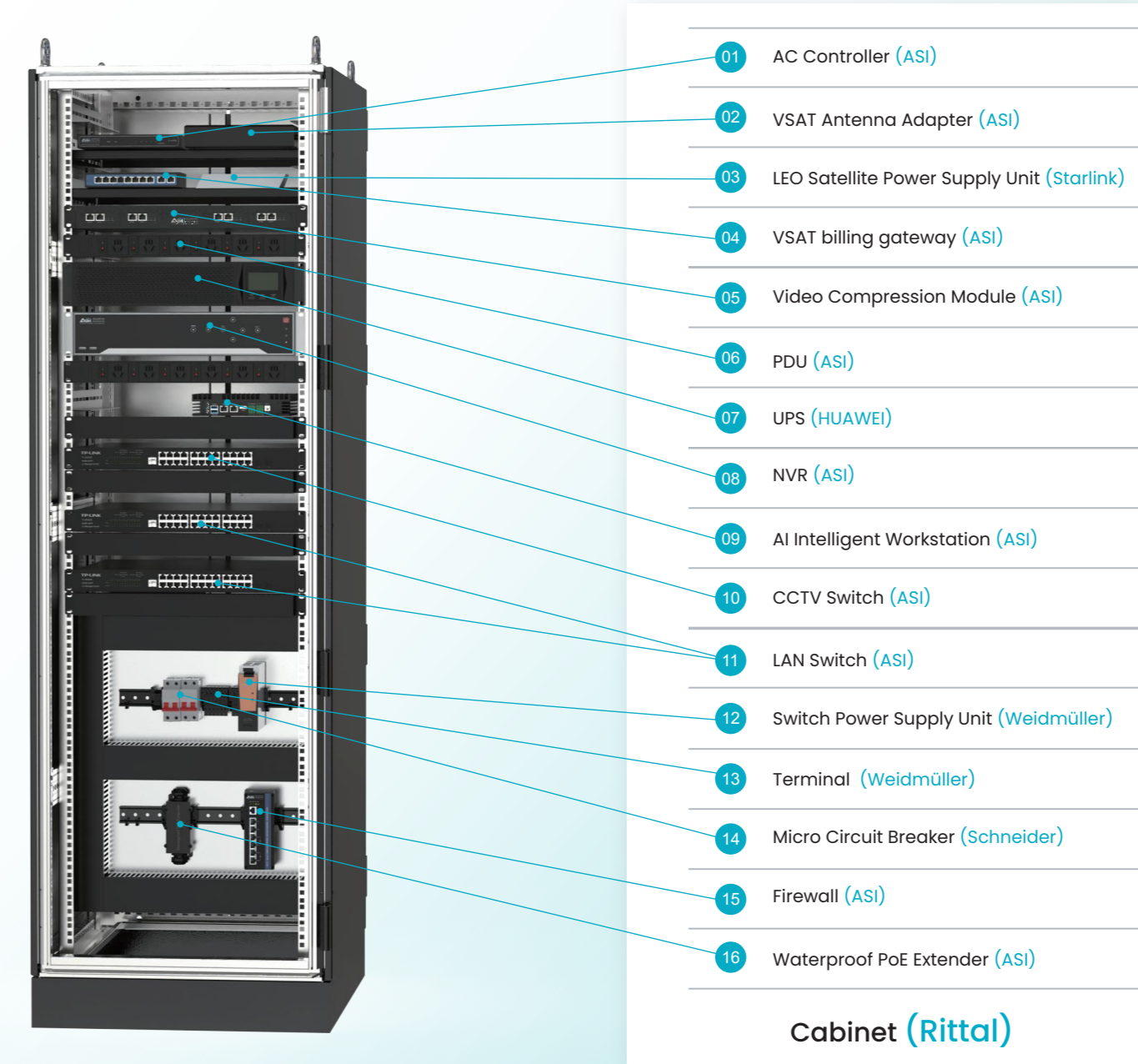

YOUR SHIP'S GUARDIAN IN THE DIGITAL AGE

# Intelligent Ship System

# 03

IACS  
UR E22

Intelligent Integration Platform、Intelligent Energy、Intelligent Machinery Software Evaluation Report & Software Testing Report



## 智能集成平台、智能能效、智能机舱 软件测评报告

项目名称	智能集成平台、智能能效、智能机舱软件测评报告
版本号	V1.0
项目编号	202503001
报告编号	CCSIC-TR-202505001
送测单位	中控海洋装备(浙江)有限公司
送测时间	2025-03-03
测评单位	中国船级社信息开发咨询中心
编制日期	2025-05-28



## 智能集成平台、智能能效、智能机舱 软件测试报告

项目名称	智能集成平台、智能能效、智能机舱软件测评
版本号	V1.0
项目编号	202503001
报告编号	CCSIC-TR-202505001
送测单位	中控海洋装备(浙江)有限公司
送测时间	2025-03-03
测试单位	中国船级社信息开发咨询中心
编制日期	2025-05-28

## 3.1 System Structure

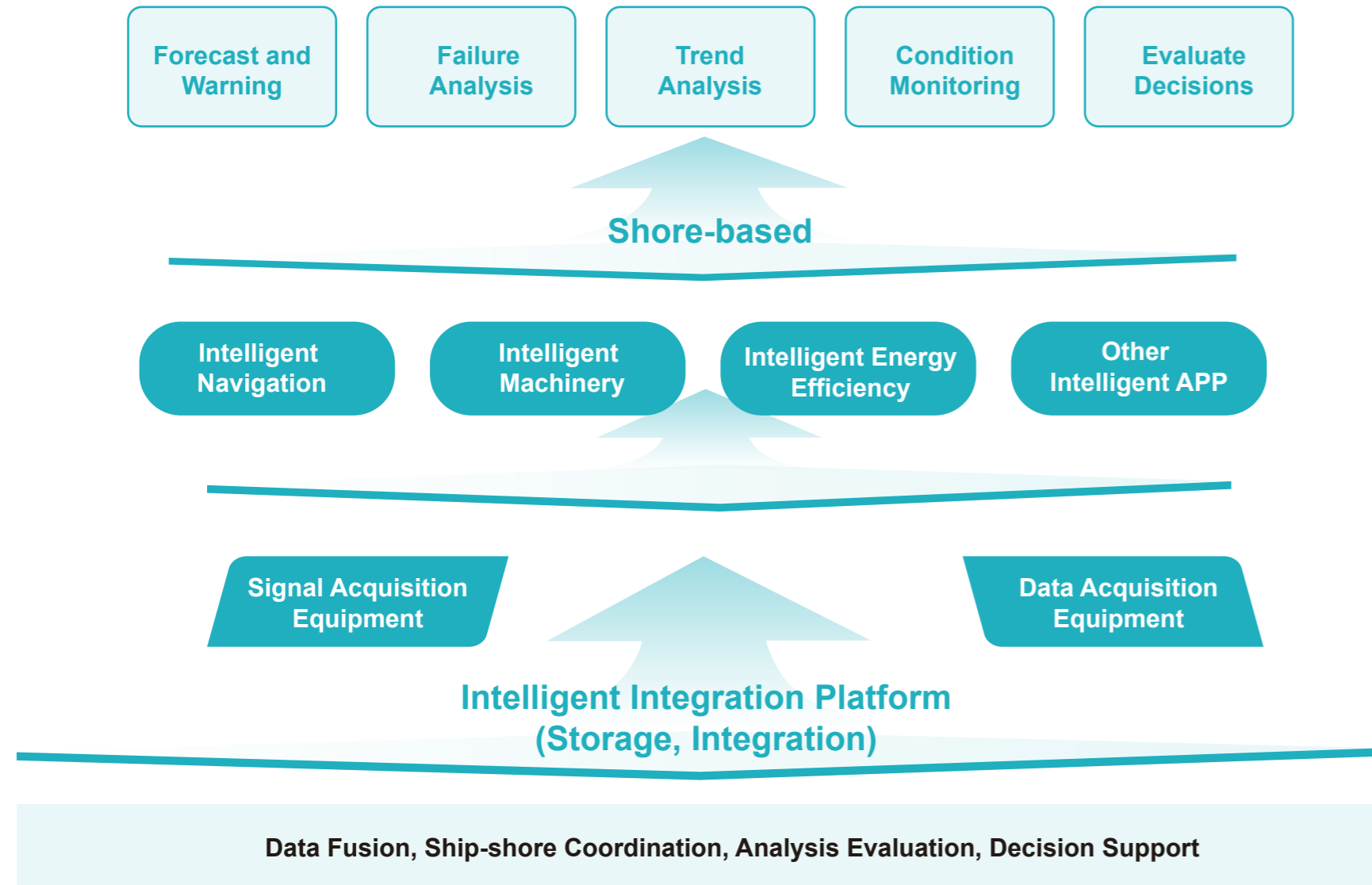

## 3.2 Data Fusion

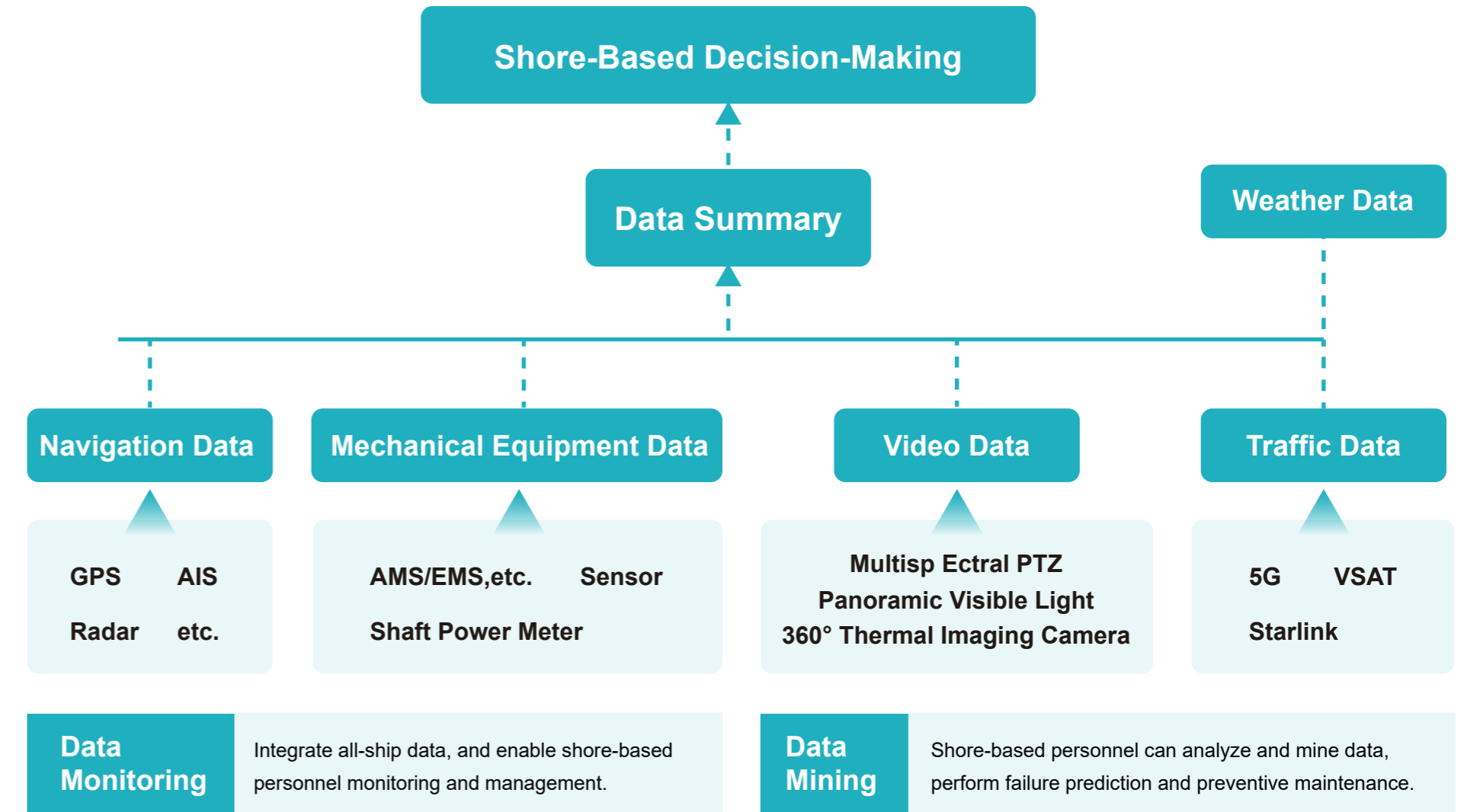

# 3.3 I/E/M Network Topology

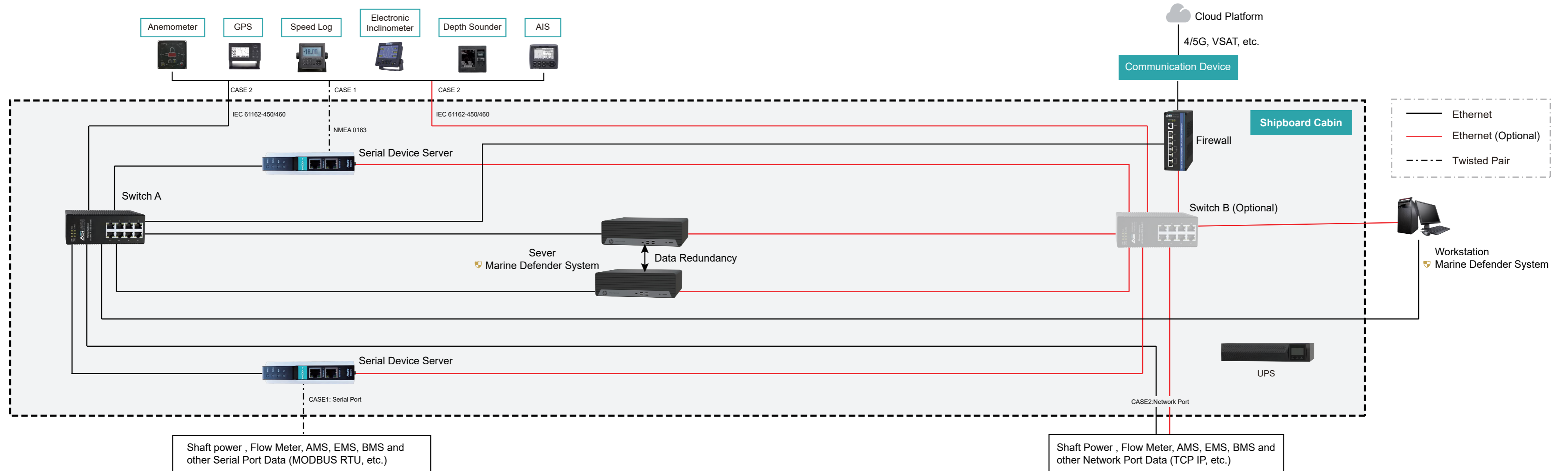

# 3.4 Intelligent Integration Platform

## System Description

01

### Data Fusion

Ship-wide multi-system data collection, storage, and integration.

02

### Intelligent Application Support

Provides computing and interaction platform for navigation/ machinery/ energy efficiency systems.

03

### Ship-Shore Interaction

Ensures stable and efficient data collaboration management between ships and shore-based.

04

### System Integration

Capable of integrating various information management systems

# Interface Presentation

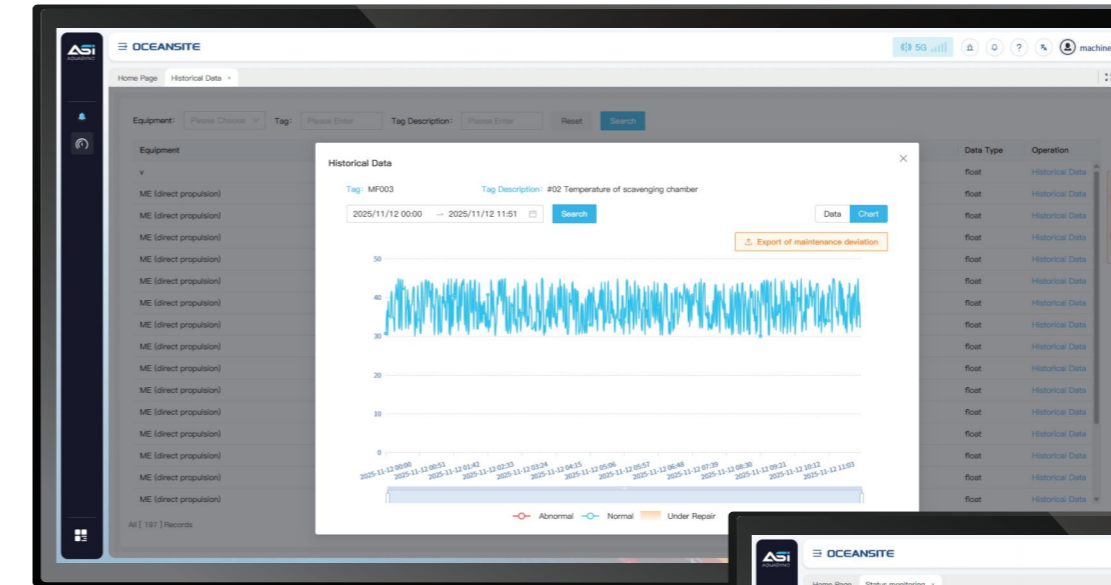

Real-time Data Charts

Overview



# 3.5 Intelligent Energy Efficiency

## System Description

01

### Voyage Data Monitoring

Real-time monitoring of man energy-consuming equipment and navigation status data.

02

### Energy Consumption Monitoring & Evaluation

Real-time display of energy consumption distribution across equipment and the ship's overall energy efficiency status.

03

### Standardized Energy Efficiency Reports

Automated generation of IMO/EU/UK-compliant energy efficiency evaluation reports.

04

### Threshold Exceedance Alarm

Notifications for exceeding limits in energy efficiency consumption, or CII (Carbon Intensity Indicator) metrics.

05

### Fuel Information Management

Management of bunkering, fuel inventory, and fuel switching operations.

## Interface Presentation

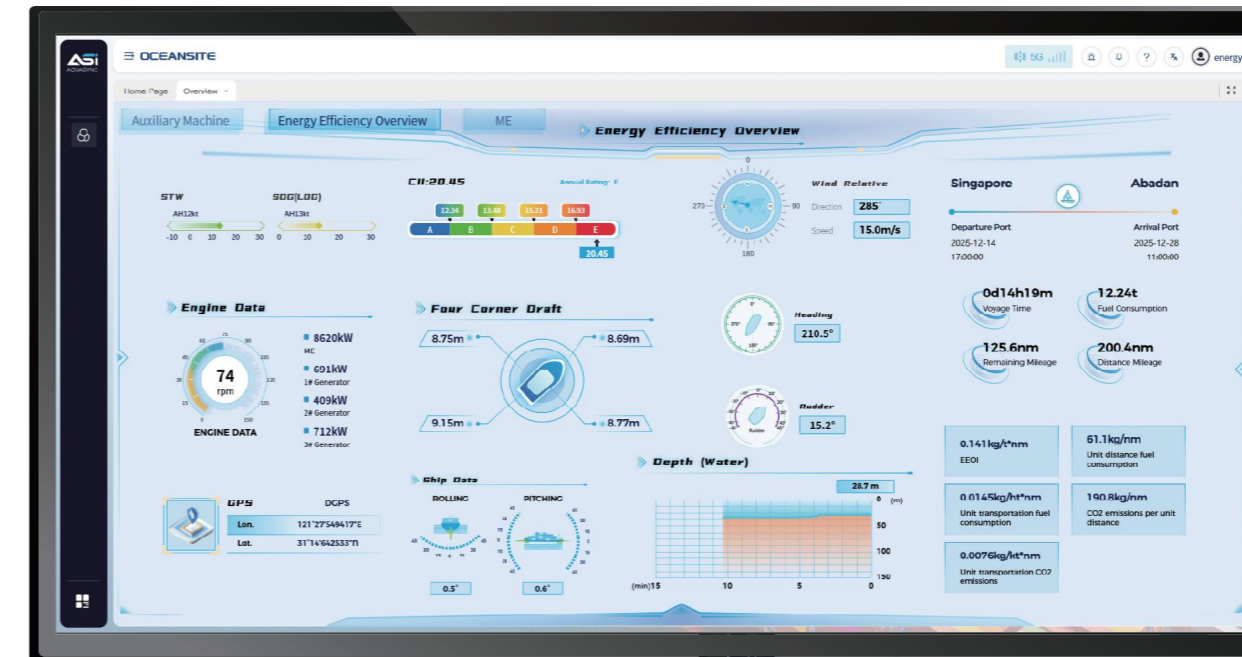

Energy Efficiency Overview

Navigation & Berthing Information

Add voy...	Company V...	Port (CN)	Port (EN)	Inside/O...	Arrival Time (LT)	Arrival ...	Departure Time (LT)	Departu...	Report ...	Status	Sailin...	Cargo/Arriv	Operations
<input type="checkbox"/>	V70-V71	新港口	NEW PORT1	Inside	2025-02-27 03:1...	East 1Z...	2025-02-27 16:1...	East 1Z...	Not Rep...	Submitted	3.00	0.00	Edit   Delete
<input type="checkbox"/>	V67-V70	新港口	NEW PORT	Inside	2025-02-25 15:5...	East 8Z...	2025-02-26 19:5...	East 8Z...	Not Rep...	Submitted	1.00	20.00	Edit   Delete
<input type="checkbox"/>	V67	德黑兰港	Port Hedlan...	Inside	2024-11-24 19:1...	East 8Z...	2024-11-25 20:2...	East 8Z...	Not Rep...	Submitted	3816.00	0.00	Edit   Delete
<input type="checkbox"/>	V67	锚碇	Anchoring	Inside	2024-11-17 13:1...	East 8Z...	2024-11-24 16:3...	East 8Z...	Not Rep...	Submitted	0.00	0.00	Edit   Delete
<input type="checkbox"/>	V67	锚碇	Anchoring	Inside	2024-11-05 16:5...	East 8Z...	2024-11-06 05:0...	East 8Z...	Not Rep...	Submitted	0.00	0.00	Edit   Delete
<input type="checkbox"/>	V67	锚碇	Anchoring	Inside	2024-11-02 20:3...	East 8Z...	2024-11-05 11:1...	East 8Z...	Not Rep...	Submitted	0.00	0.00	Edit   Delete
<input type="checkbox"/>	V66-V67	丹东	DANQONG	Inside	2024-10-27 19:1...	East 8Z...	2024-10-30 13:0...	East 8Z...	Not Rep...	Submitted	3714.00	173123.00	Edit   Delete
<input type="checkbox"/>	V66	锚碇	Anchoring	Inside	2024-10-20 15:0...	East 8Z...	2024-10-27 13:4...	East 8Z...	Not Rep...	Submitted	0.00	0.00	Edit   Delete
<input type="checkbox"/>	V66	丹波尔	Dampier, Wa	Inside	2024-10-03 15:3...	East 8Z...	2024-10-04 23:0...	East 8Z...	Not Rep...	Submitted	3859.00	0.00	Edit   Delete
<input type="checkbox"/>	V66	锚碇	Anchoring	Inside	2024-09-30 15:4...	East 8Z...	2024-10-03 12:1...	East 8Z...	Not Rep...	Submitted	0.00	0.00	Edit   Delete
<input type="checkbox"/>	V65-V66	碧色港	Bayawan	Inside	2024-09-15 22:1...	East 8Z...	2024-09-15 08:4...	East 8Z...	Not Rep...	Submitted	566.00	116014.00	Edit   Delete

# 3.6 Intelligent Machinery

## System Description

01

### Equipment Status Monitoring

Monitors the operational status of major propulsion-related equipment and systems in the cabin.

02

### Health Analysis

Intelligently analyzes and evaluates the health status of equipment and systems.

03

### Knowledge Base

Continuously accumulates expert experience to provide decision-making recommendations.

04

### Decision Support

Assists crew in quickly identifying and resolving issues.

# Interface Presentation

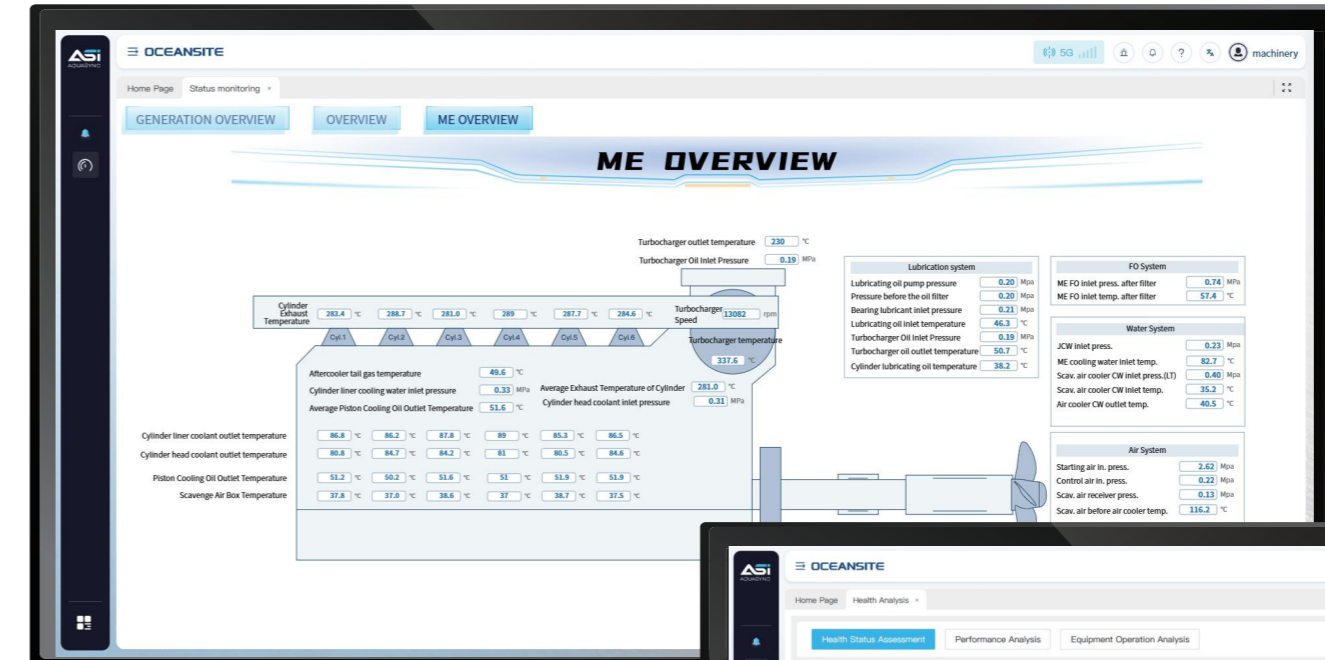

Status Monitoring

Health Analysis

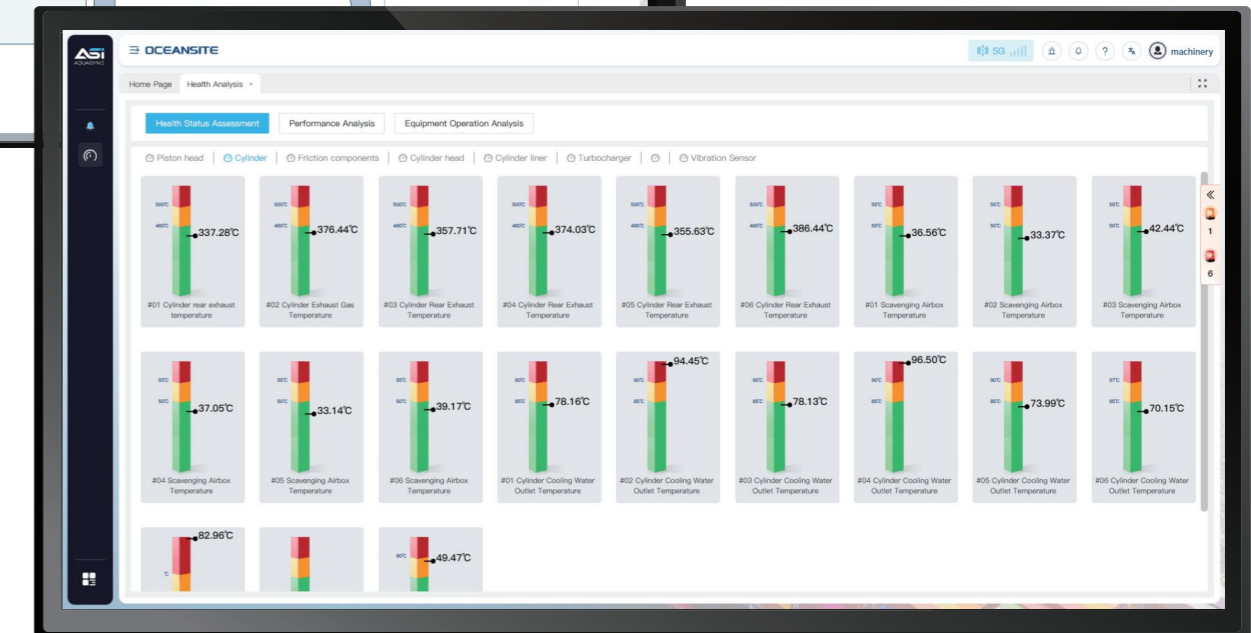

# 3.7 Intelligent Navigation

## System Description

▶ 01 ◀

**Route & Speed Optimization**

Automatically plans optimal routes and speeds by integrating ECDIS/ meteorological data.

▶ 02 ◀

**Collision/Grounding Warning**

Intelligent obstacle avoidance system based on AIS/radar/water bathymetry data

▶ 03 ◀

**Visual Enhancement**

Provides crew with augmented perception in rain, snow, fog, low-light, and adverse weather conditions.

▶ 04 ◀

**Voyage Information Visualization**

Integrated dashboard displaying navigational alerts/environmental data

# Intelligent Navigation Network Topology

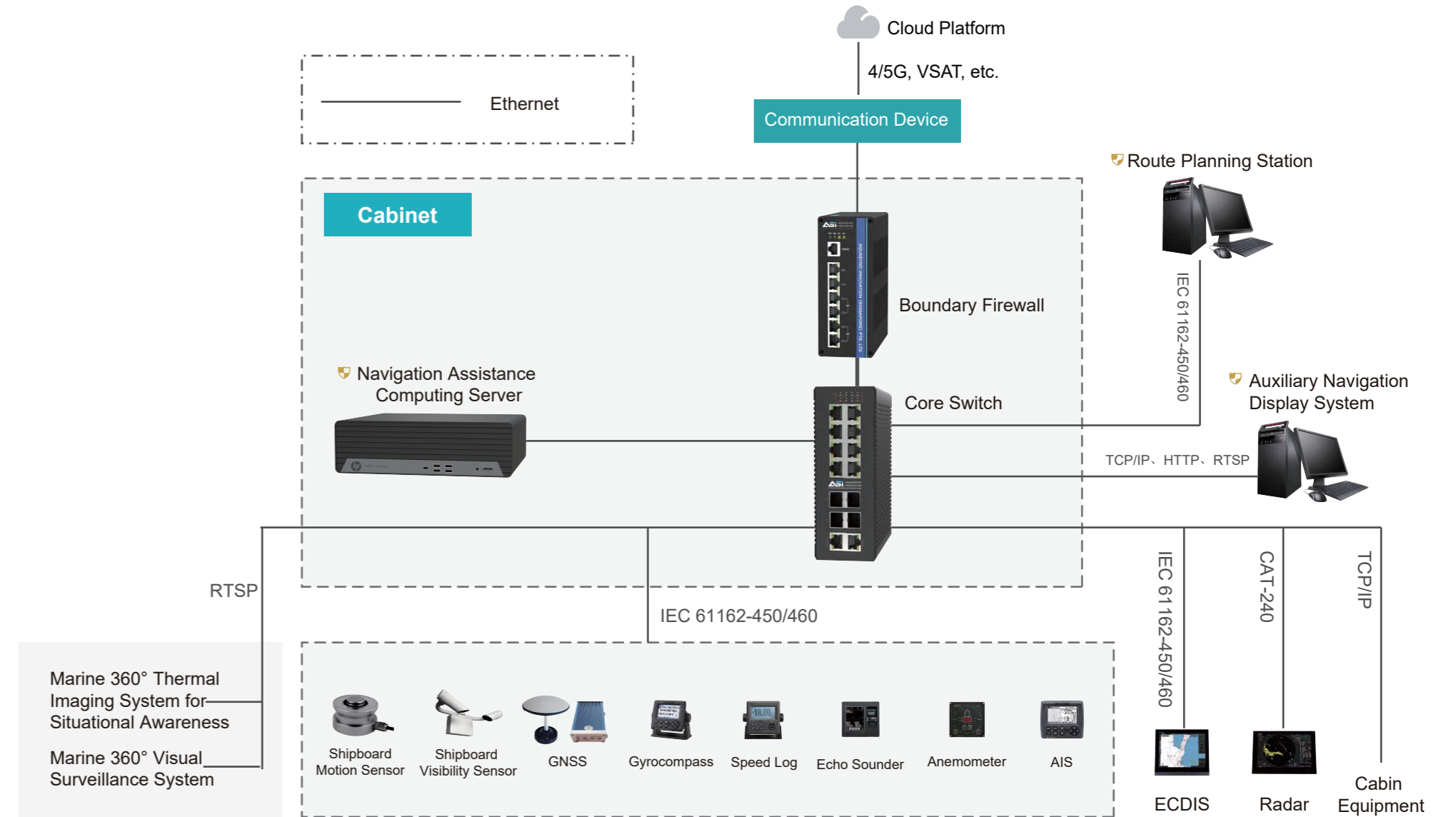

YOUR SHIP'S GUARDIAN IN THE DIGITAL AGE

# Ship-Fleet Management System

Certificate Of Type Approval Forthe Management System (Software)ofpms (Planned Maintenance System)

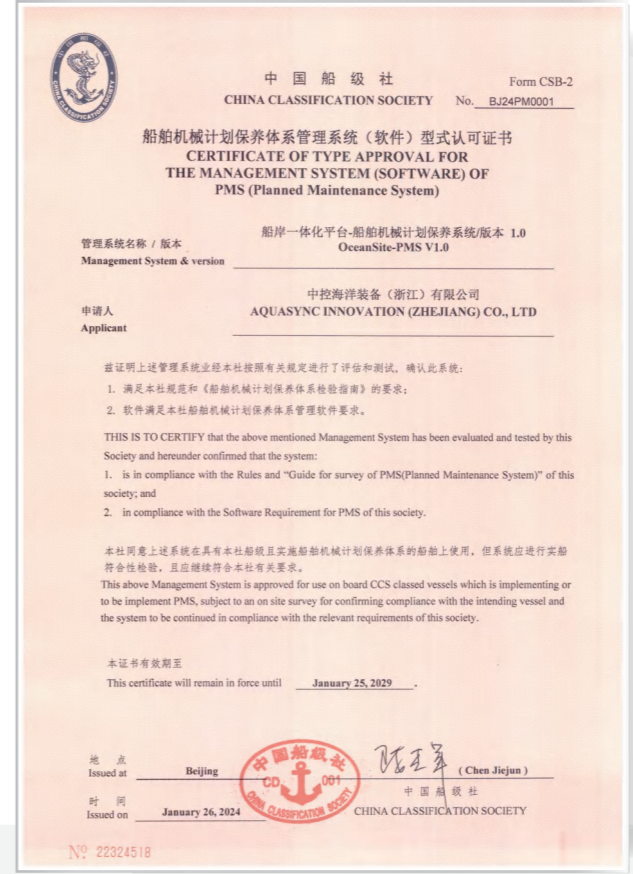

AquaSync Innovation MRV Energy Efficiency Management System



# 4.1 Network Topology

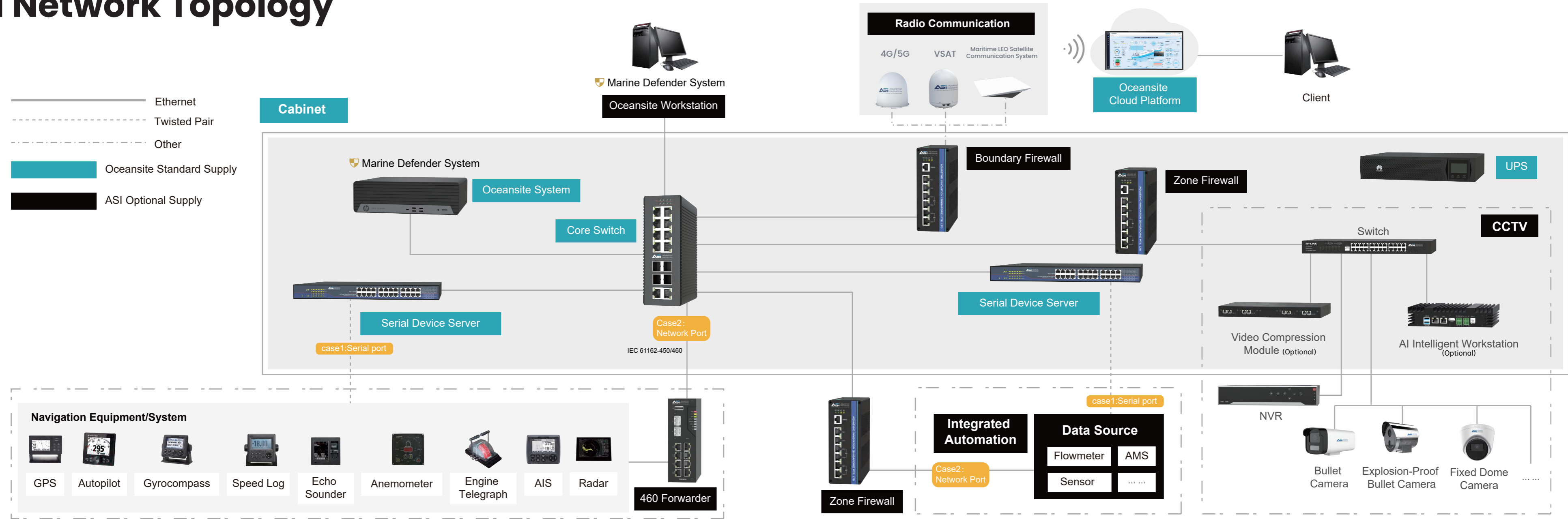

# 4.2 Infrastructure

## Oceansite Standard Supply

01



Oceansite Platform Server

02



UPS

03



Serial Device Server

04



Core Switch

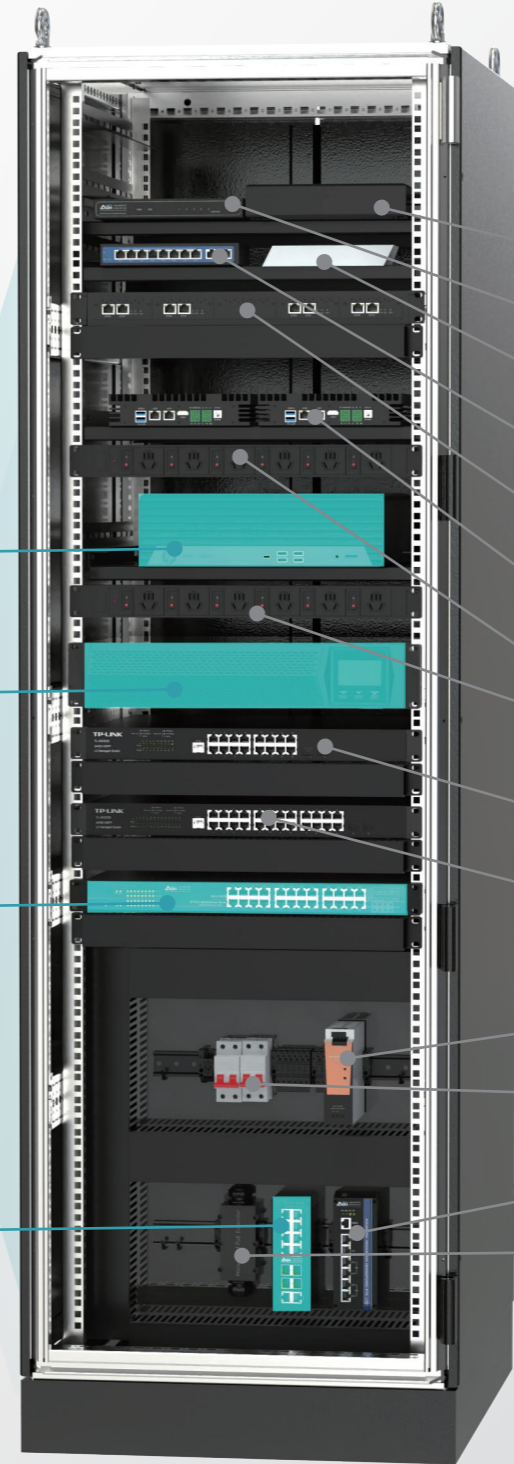

ASI Optional Supply	
01	VSAT Antenna Adapter
02	WLAN Access Controller Manager
03	LEO Satellite Power Supply Unit
04	VSAT billing gateway
05	Video Compression Module
06	AI Intelligent Workstation
07	PDU
08	CCTV Switch
09	LAN Switch
10	Switch Power Supply Unity
11	Micro Circuit Breaker
12	Firewall
13	Waterproof PoE Extender

# 4.3 System Architecture

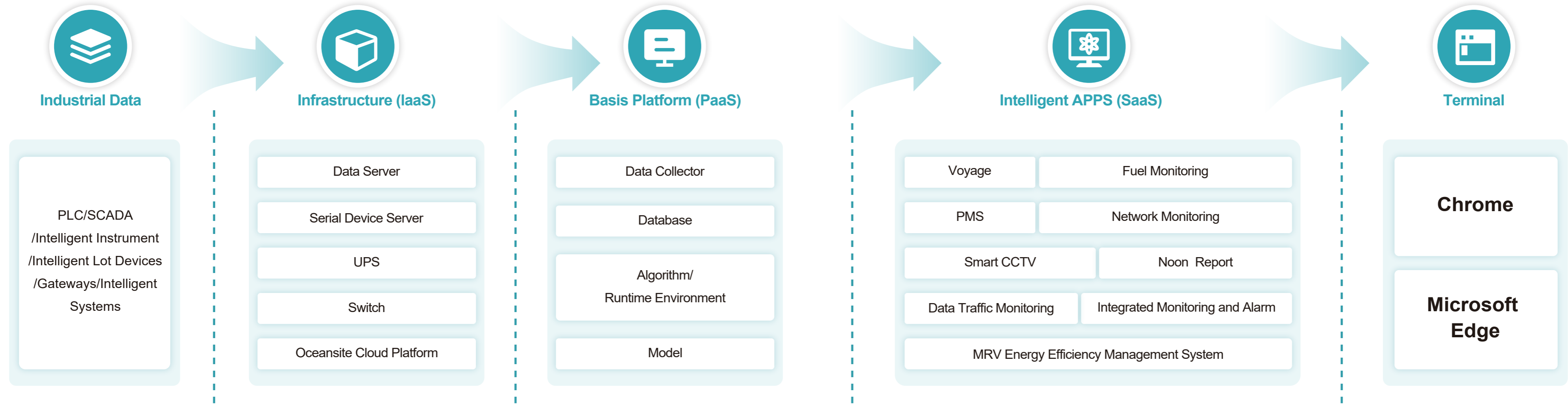

# Fleet Management

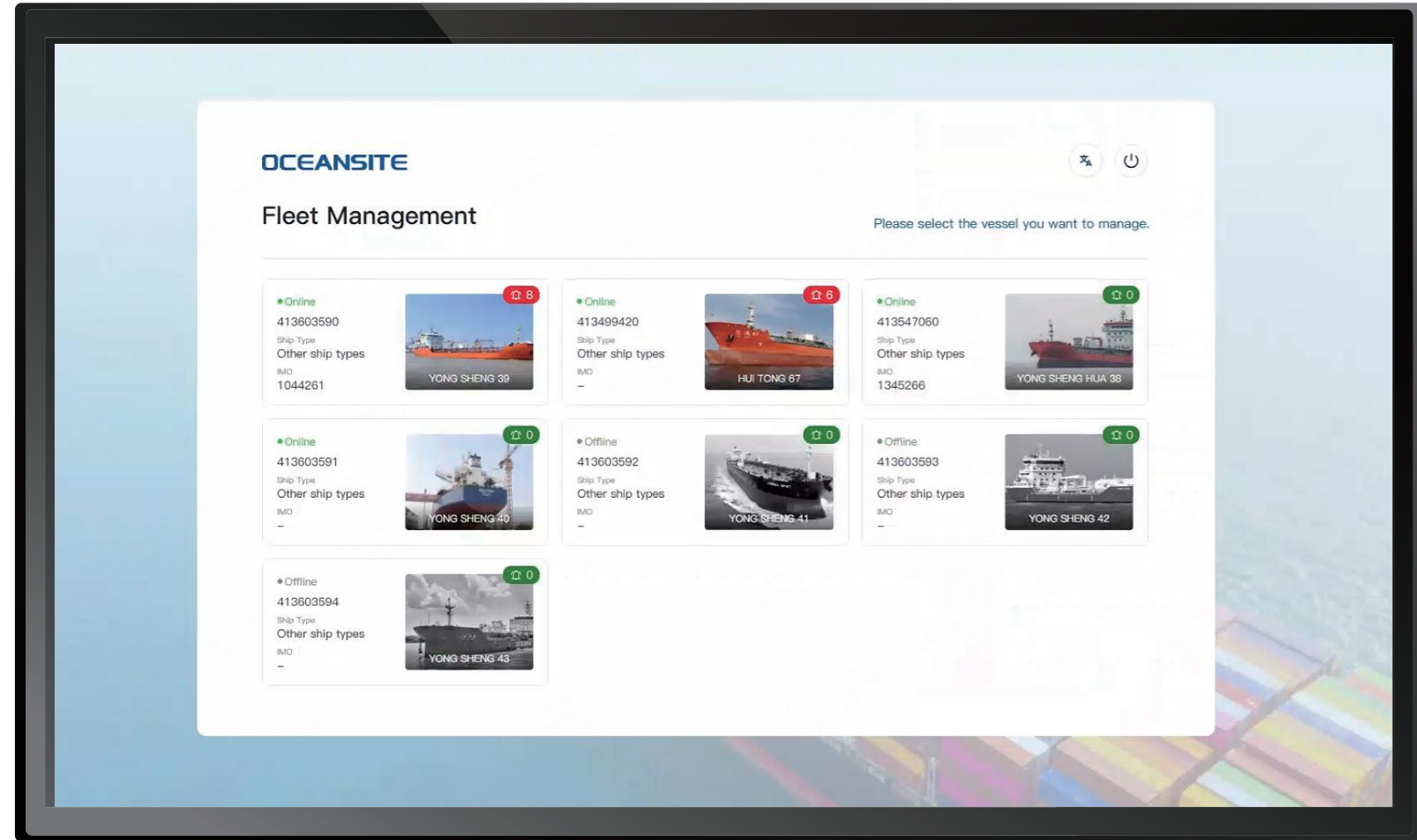

Fleet List

Switch Freely

# Voyage Data Visualization

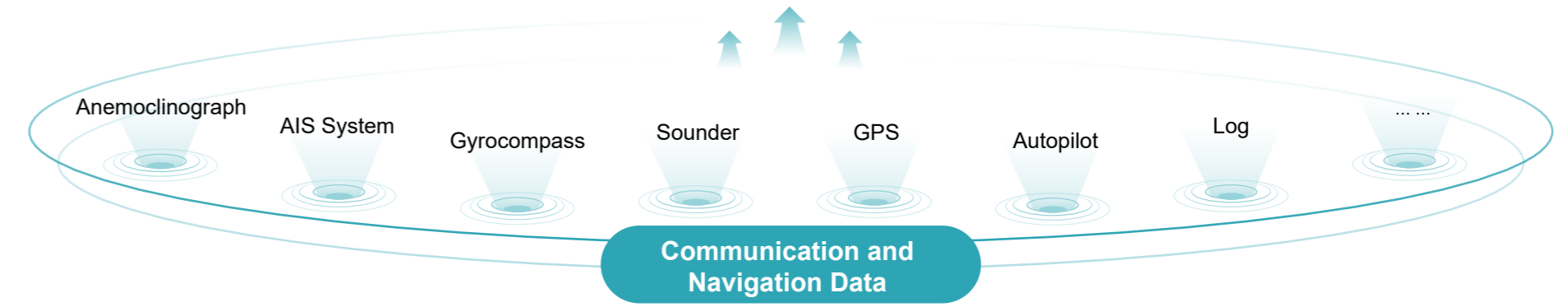
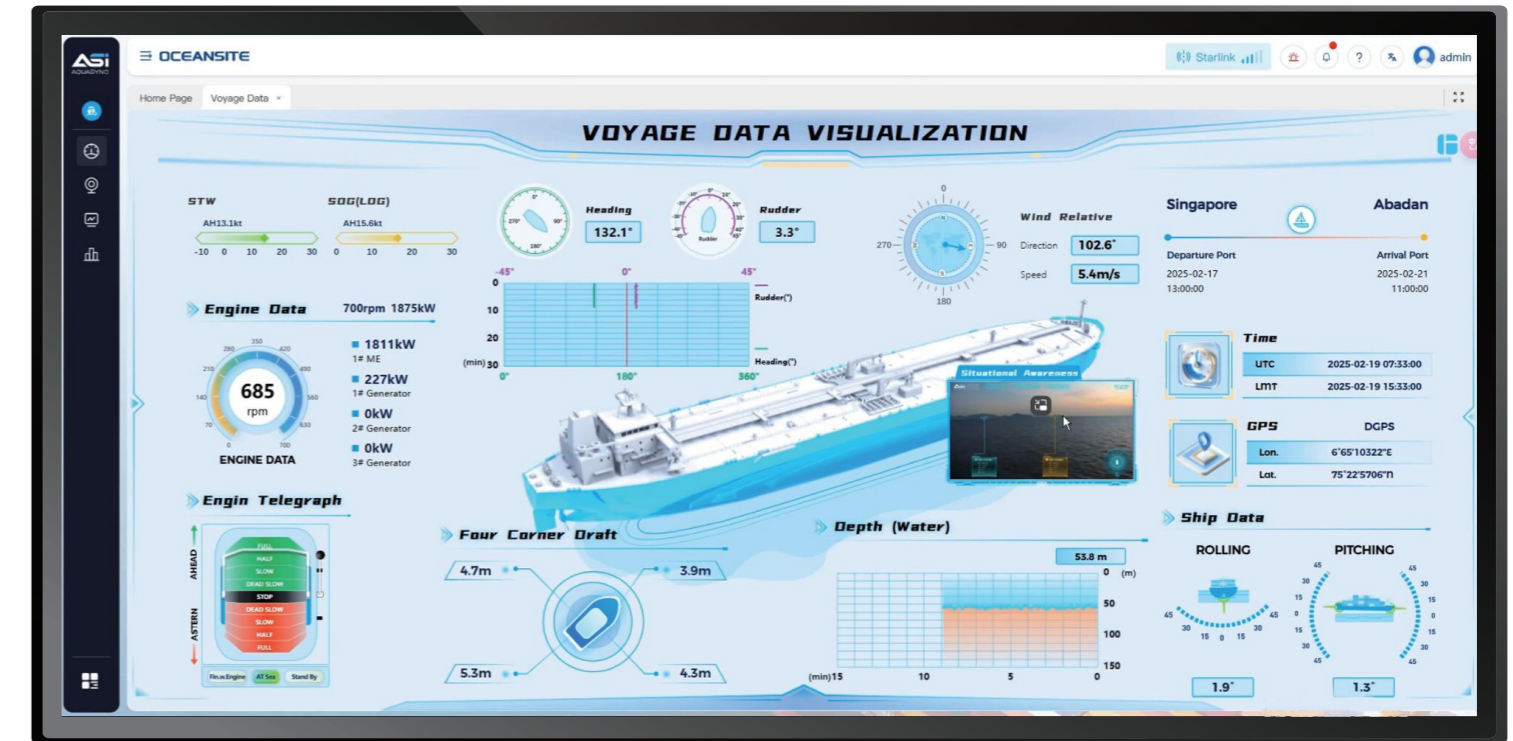

# Electronic Chart

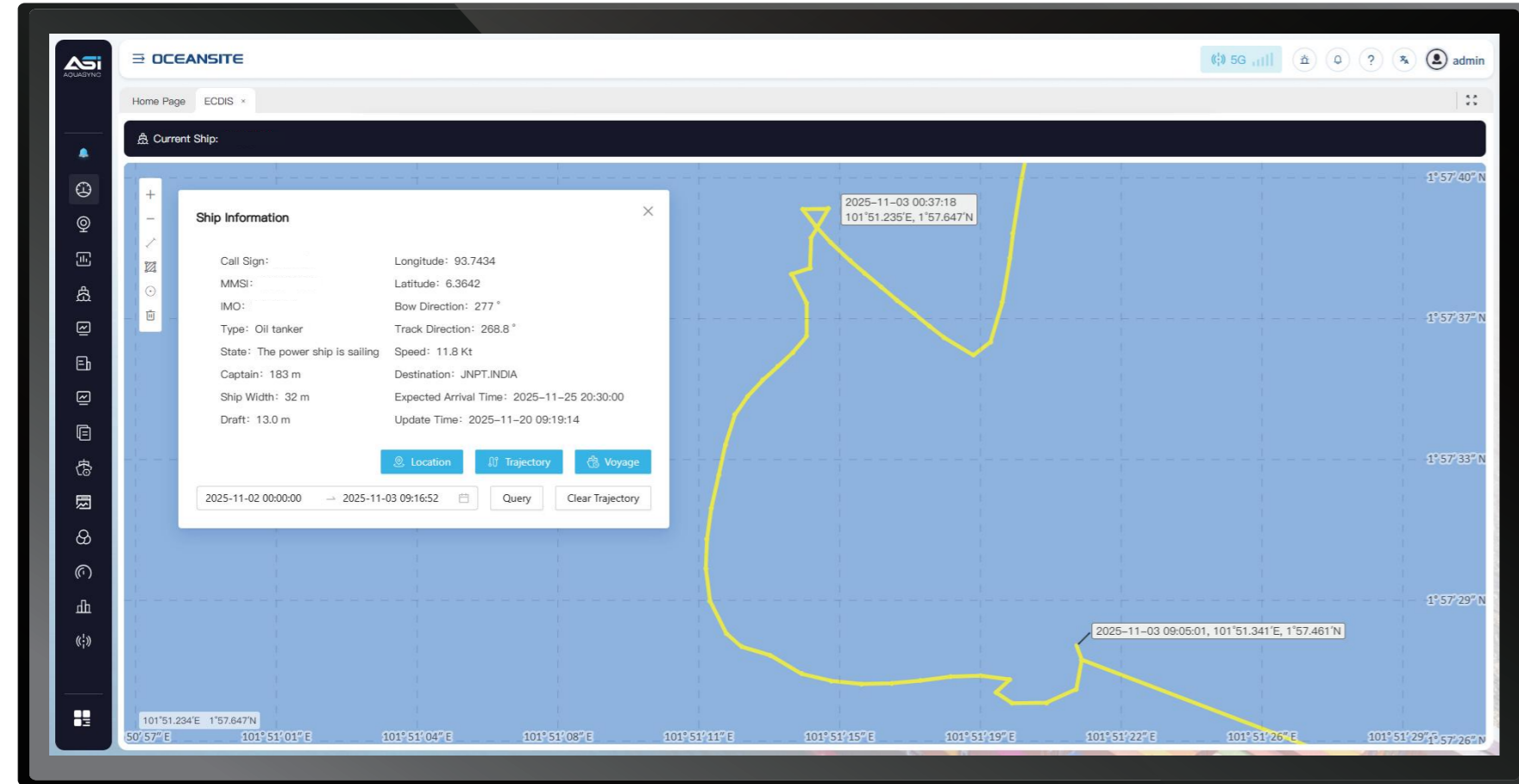

Global Online Nautical Chart

Ship Position Information

Trajectory Information

Display of Signal Overlay Trajectory

# Smart CCTV

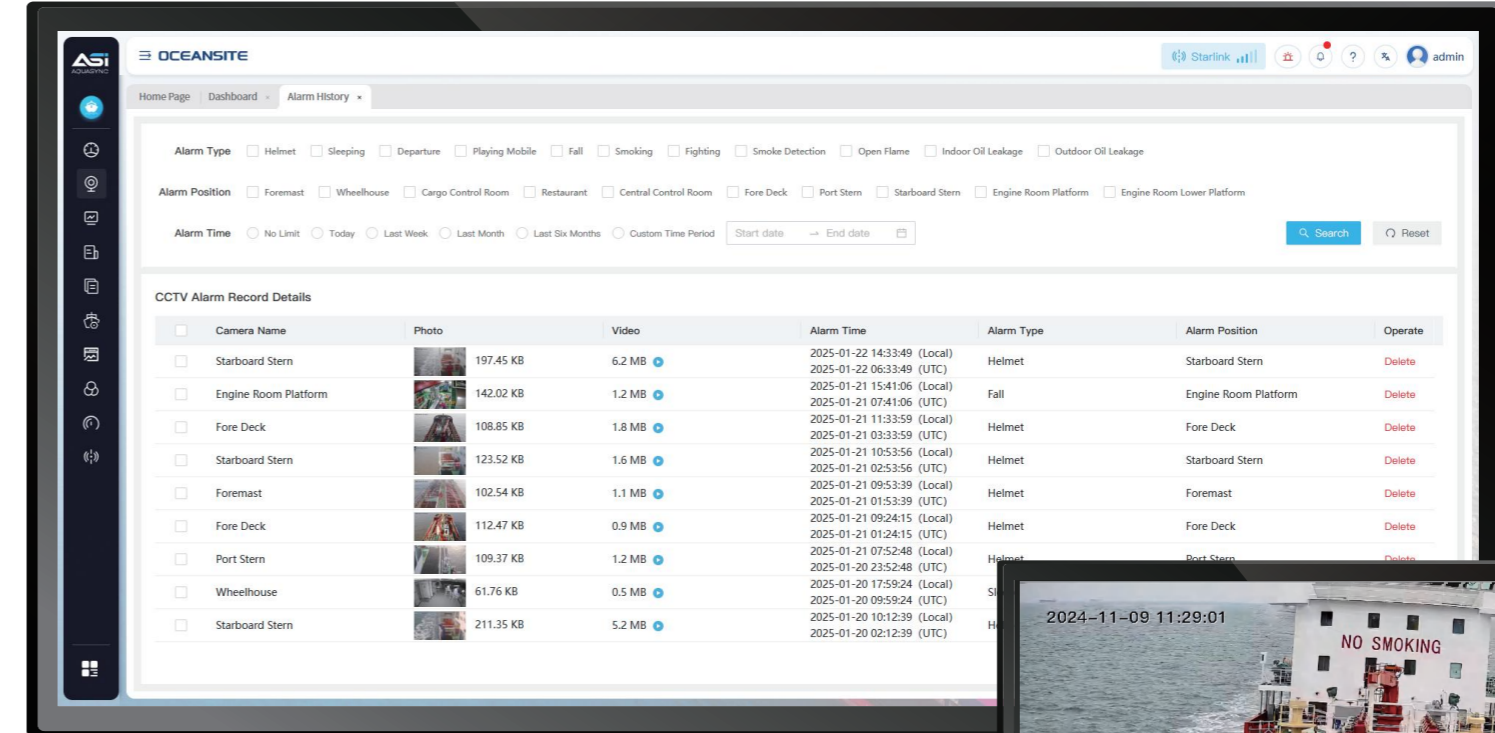

## Alarm Notification

Video alarms for unsafe behaviors can be alerted in real-time through system messages.

## Alarm Record

The system will automatically record screenshots and video clips of unsafe behaviors and support preview.



Unsafe Behavior Photos

YOUR SHIP'S GUARDIAN IN THE DIGITAL AGE

# Ship Cybersecurity Solution

## 5.1 IACS UR E26&E27

	IACS UR E26 (Ship Cyber Resilience)	IACS UR E27 (On-Board Systems Cyber Resilience)
<b>Scope</b>	Whole-Ship Cyber Resilience (Ship Level)	Individual CBS Certification (System & Equipment Level)
<b>Core Objective</b>	Secure and Dependable Maritime Transport	CBS & Equipments
<b>Key Requirements</b>	① Identify ② Protect ③ Detect ④ Respond ⑤ Recover	① Identification and Authentication ② Access Control ③ System Integrity ④ Data Confidentiality ⑤ Restricted Data Flow ⑥ Timely Response to Events ⑦ Resource Availability
<b>Certifications</b>	- ISO/IEC 17025 (DNV&CNAS) - ISO/IEC 27001 :2022 - Personnel: CISSP - ISO/IEC 20000-1:2018	- IEC 62443-4-1 & 4-2 & 2-4 - ISO/IEC 27001 :2022 - IACS UR E10 - ISO/IEC 20000-1:2018
<b>Testing Requirements</b>	Whole-Ship Cyber Resilience Testing	Individual Equipment Functionality & Security Testing
<b>Deliverables</b>	<ul style="list-style-type: none"> <li>- Approved supplier documentation</li> <li>- Zones and conduit diagram</li> <li>- Cyber security design description</li> <li>- Vessel asset inventory</li> <li>- Risk assessment for the exclusion of CBSs</li> <li>- Description of compensating countermeasures</li> <li>- Ship cyber resilience test procedure</li> <li>- Ship cyber security and resilience program</li> </ul>	<ul style="list-style-type: none"> <li>- CBS Asset Inventory</li> <li>- Topology Diagrams</li> <li>- Description of Security Capabilities</li> <li>- Test Procedure for Security Capabilities</li> <li>- Security Configuration Guidelines</li> <li>- Secure Development Lifecycle</li> <li>- Plans for Maintenance and Verification</li> <li>- Information Supporting Incident Response and Recovery Plans</li> <li>- Management of Change Plan</li> <li>- Test Reports</li> </ul>

” Effective Period: Ships Contracted for Construction on or After 1 July 2024.”

# 5.2 Ship Cybersecurity (IT+OT) Solution-ASI

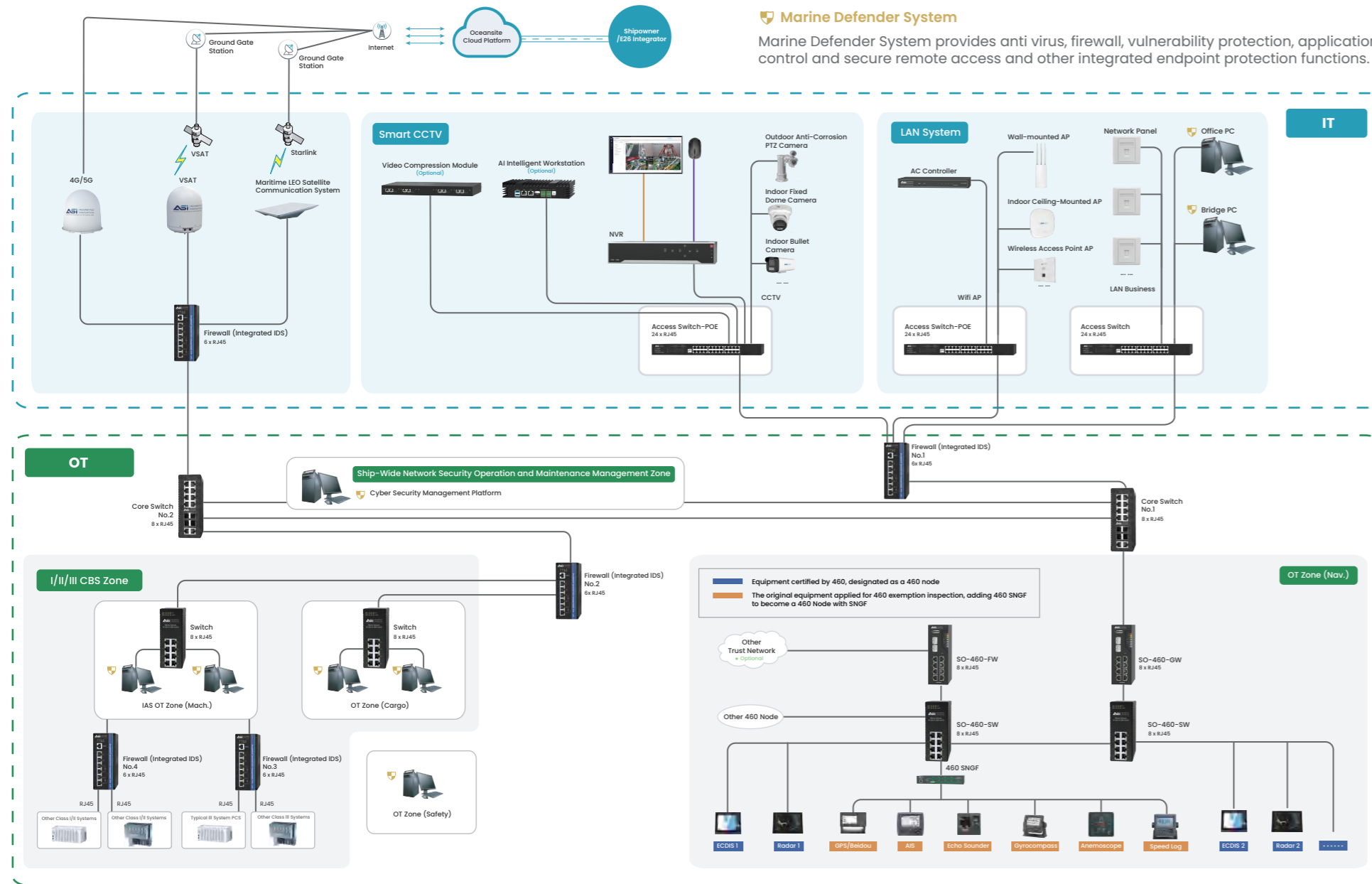

## IT Cabinet

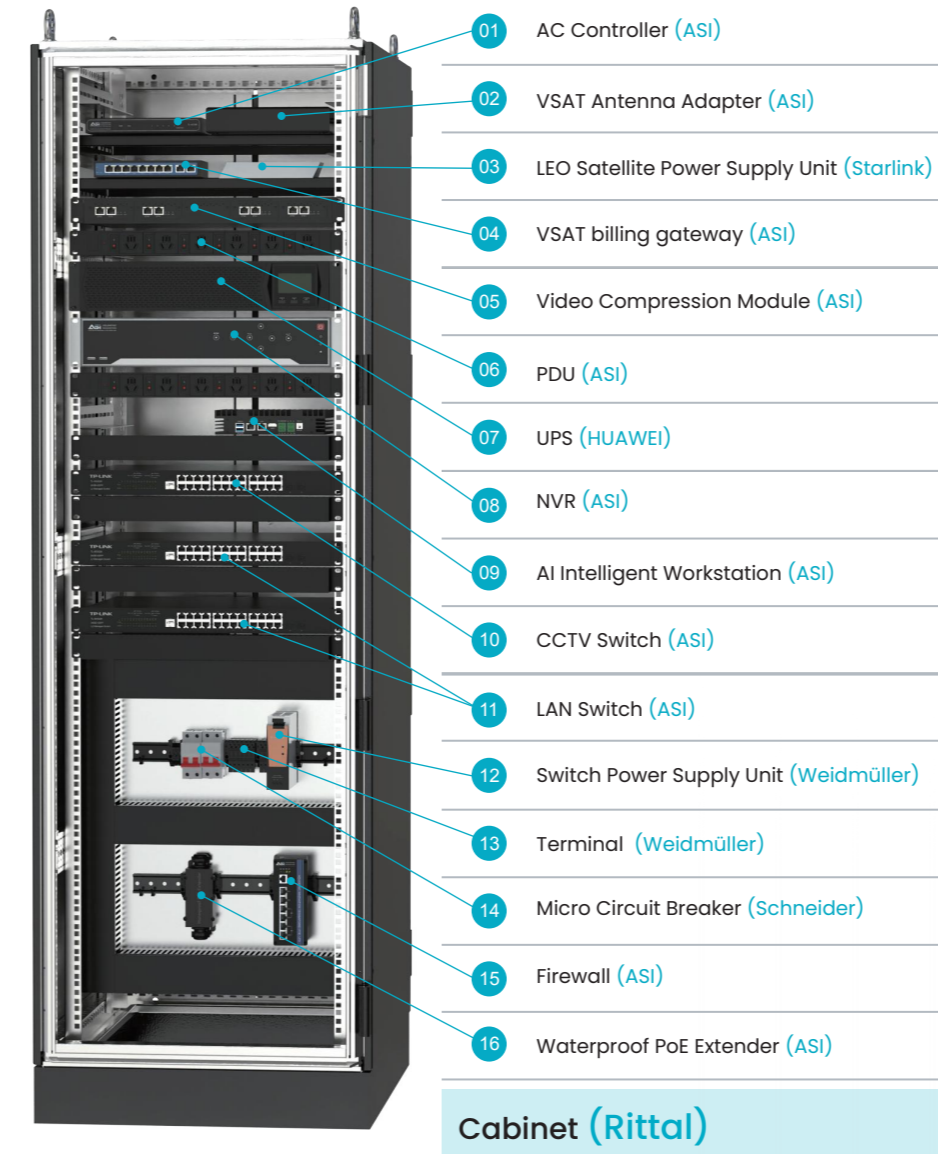

## Cybersecurity Cabinet

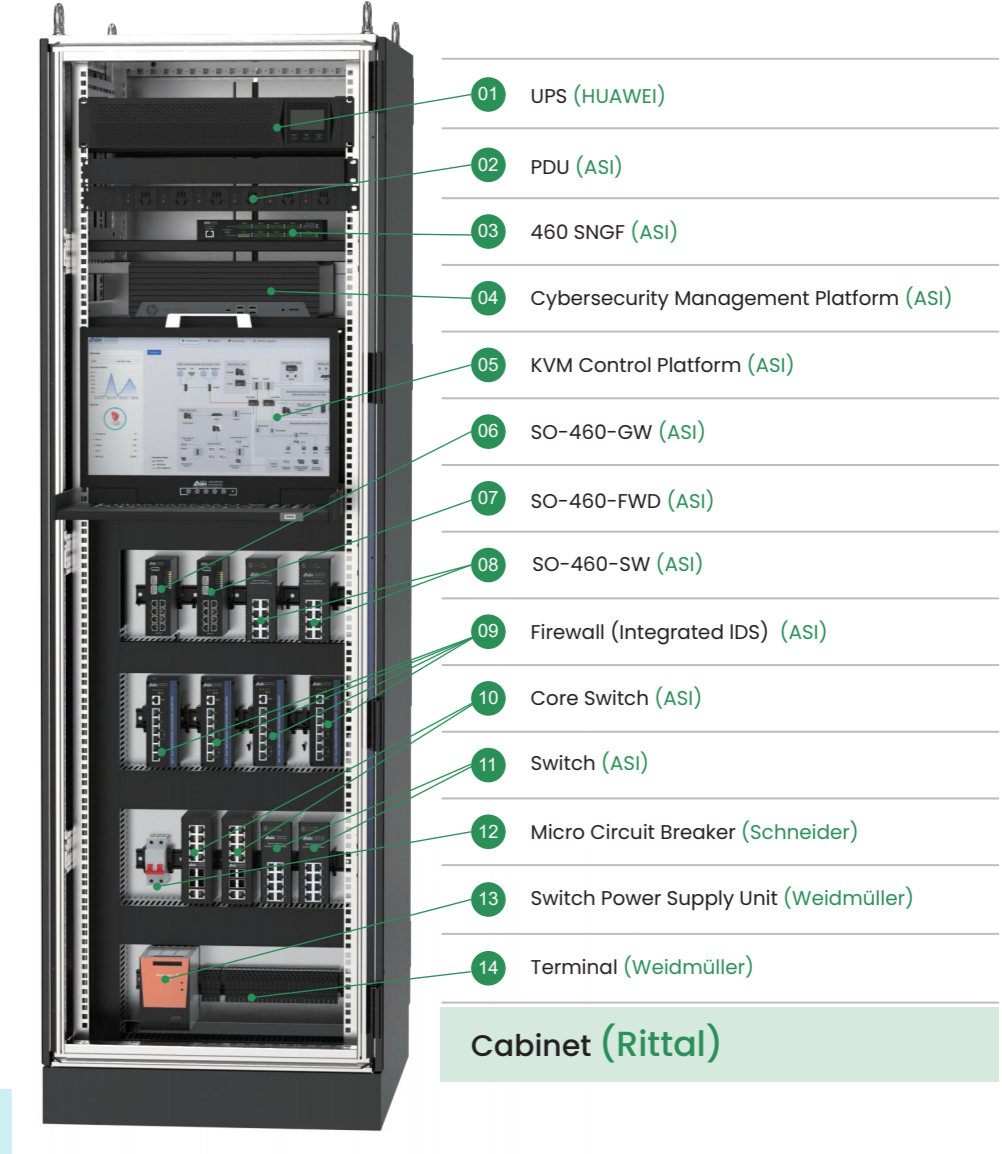

# 5.3 Ship Cybersecurity (IT+OT) Solution- Fortinet

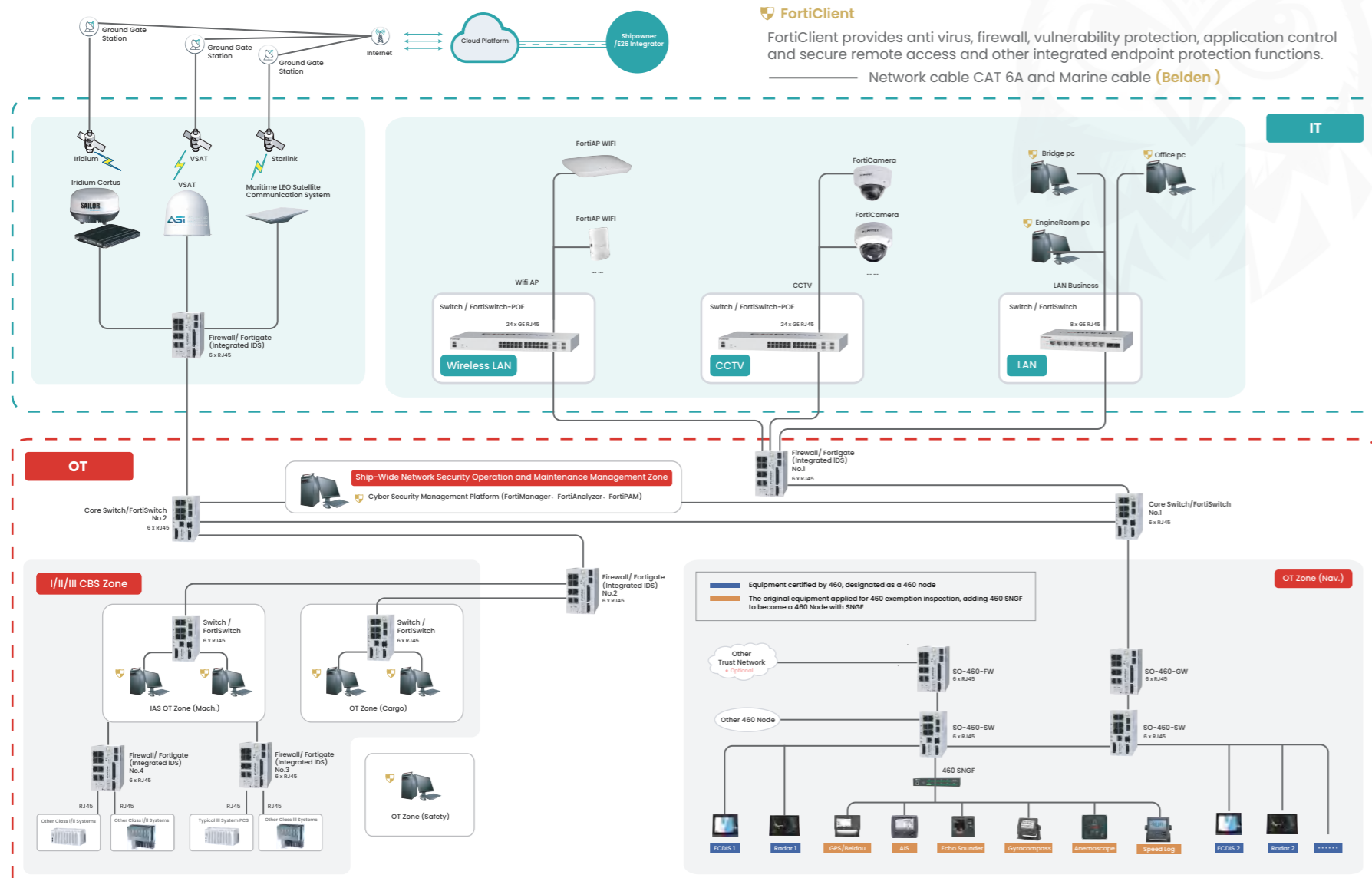

## IT Cabinet

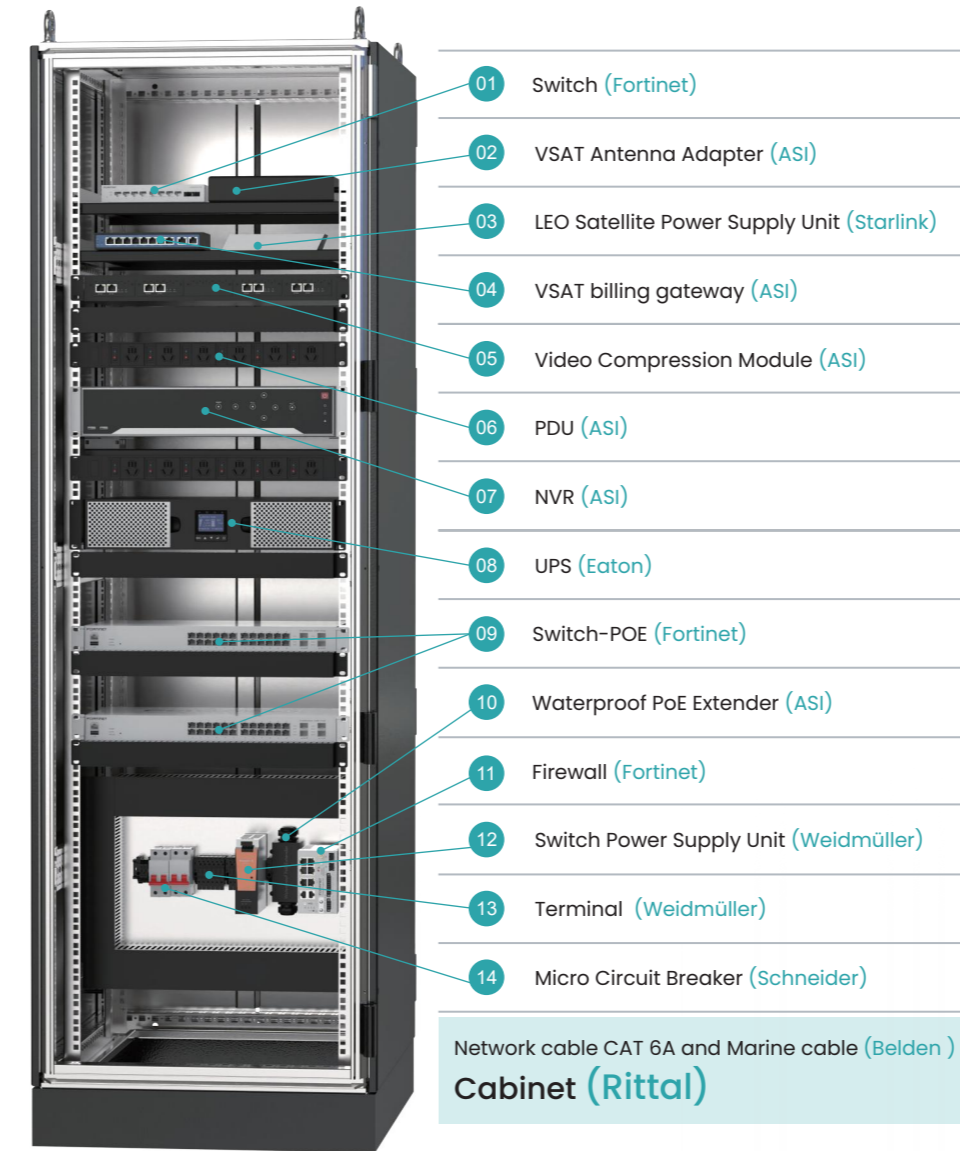

## Cybersecurity Cabinet

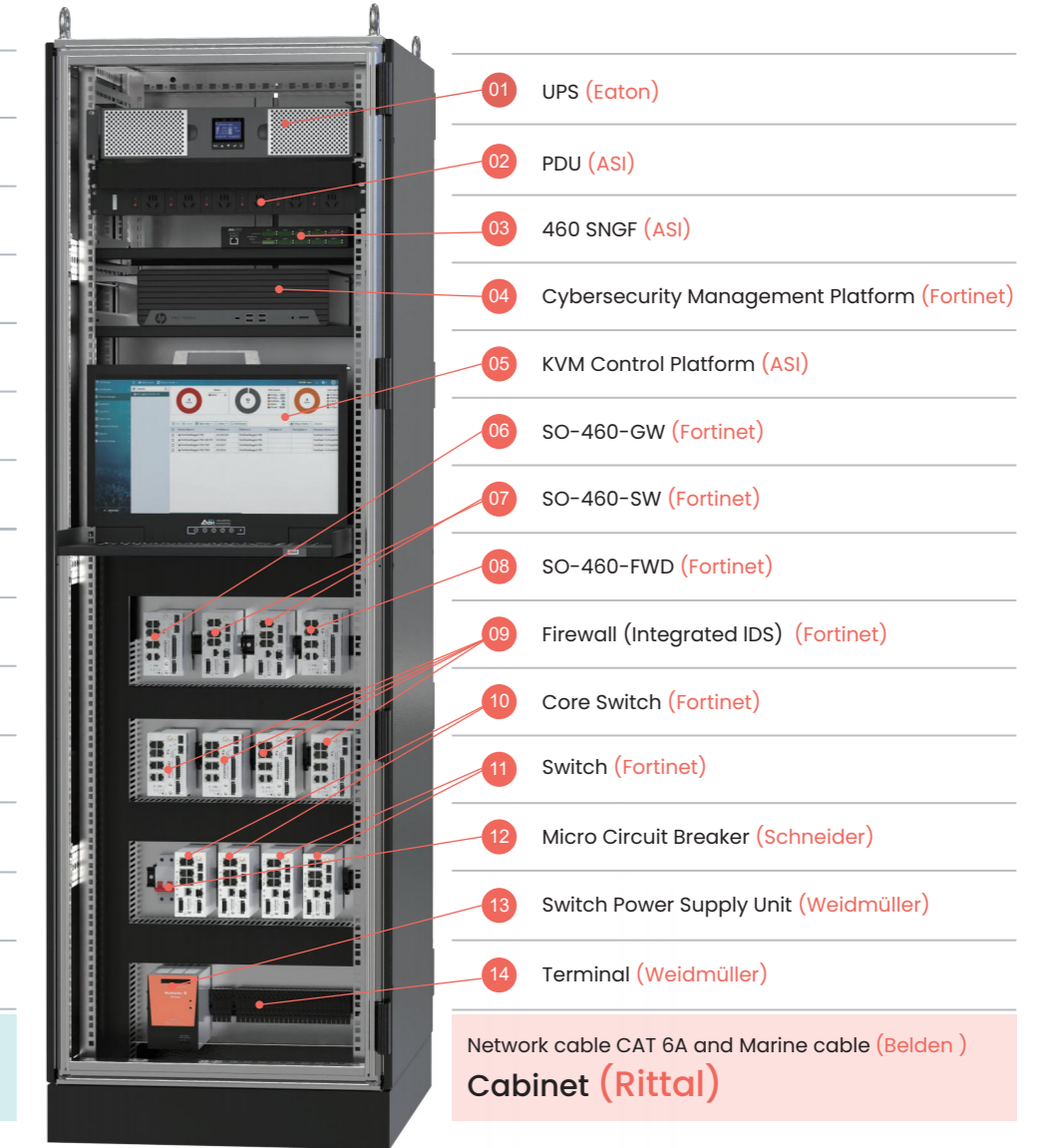

# 5.4 Main Classification Society Registration Symbols

China Classification Society (CCS)		
The Additional Notation for Ship Cybersecurity.	The Ship Cyber Resilience Level.	
	Ship-Level	CBS-Level
M	Compliant With Cyber Risk Management.	-
P	SL0 (Corresponding to IACS UR E26).	SL0 (Corresponding to IACS UR E27).
S	SL1	SL1
	SL2	SL2
	SL3	SL3
	SL4	SL4

Det Norske Veritas (DNV)		
Class Notation (Default Suc)	Security Profile	Class Notation (Additional Systems)
Cyber Secure	SP0	(+) (+)
Cyber Secure (Essential) (Corresponding to IACS UR E26 & E27).	SP1	
Cyber Secure (Advanced)	SP2	
	SP3	
	SP4	

# 5.5 Golden Triangle Alliance for a Comprehensive E26/27 Solution



### SOLUTION DESIGN

- ASI x DNV
- Ship Asset Inventory
- Ship Network Topology Diagram
- Ship Cybersecurity Design Description
- Risk Assessment for the Exclusion of CBSs (If applicable)
- Description of Compensating Countermeasures (If applicable)
- Ship Cybersecurity Testing Procedure
- Template File for Ship Cybersecurity and Resilience
- ISO/IEC 27001 : 2022
- Certified Personnel: CISSP

### CYBERSECURITY TEST SERVICE

- ASI x DNV
- Providing Cybersecurity Capability Testing Based on Approved Test Procedures
- ISO/IEC 17025:2017(DNV&CNAS)
- Tester : CISSP

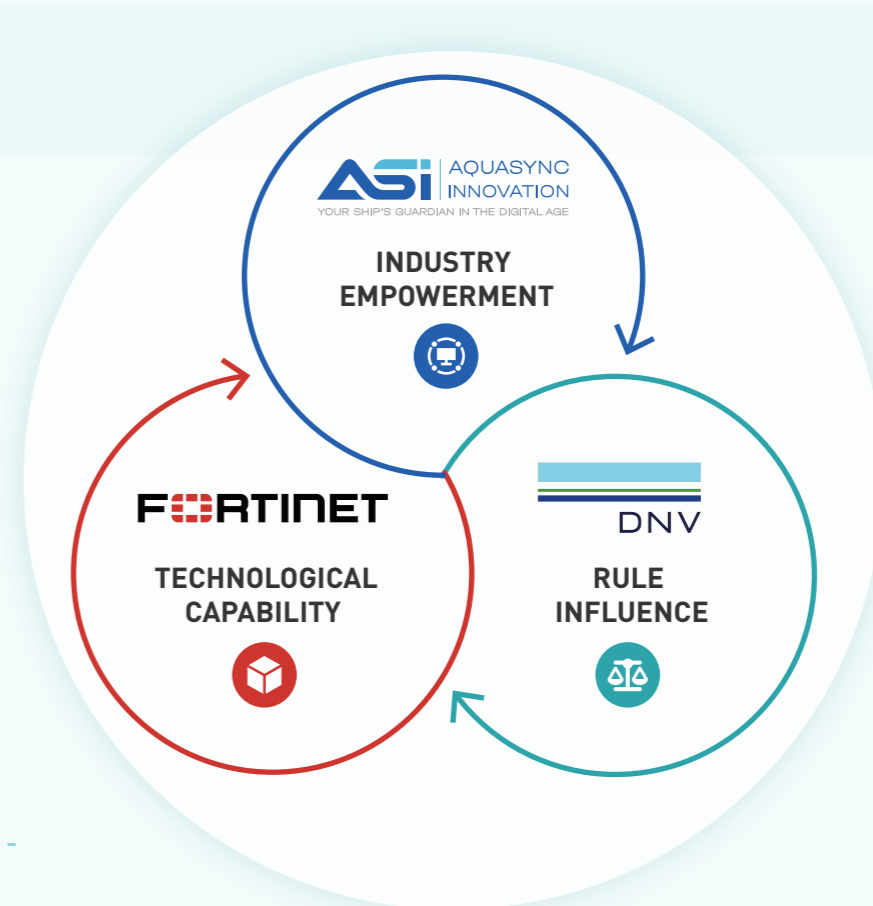

### PROVISION OF HARDWARE

- ASI x FORTINET
- Marine Network Core Switch
- Marine Network Firewall
- Marine Defender System
- Cybersecurity Management Platform
- 460-Gateway
- 460-Switch
- 460-Forwarder
- 460-SNGF
- IEC 62443-4-1
- IEC 62443-4-2
- IEC 61162-460

### OPERATIONAL MAINTENANCE SERVICES

- ASI x FORTINET x DNV
- Cybersecurity Operational Maintenance Services
- ISO/IEC 20000:2018
- IEC 62443-2-4
- ISO/IEC 17025:2017(DNV&CNAS)
- Certified Personnel: CISSP

All based on: ISO 9001 : 2015

# JOINT TENDER AGREEMENT



## Solution Design

Providing Comprehensive Cybersecurity Solution Design for Vessels in Compliance with E26 Requirements

## Hardware Provision

Providing Cybersecurity Devices Compliant with IEC 62443-4-1 and IEC 62443-4-2 Requirements

## Cybersecurity Test Service

Providing Cybersecurity Capability Testing Based on Test Procedure

## Operational Maintenance Services

Cybersecurity Operations and Annual Assessment

## 联合体协议书 Consortium Agreement

船舶网络安全E26&E27咨询测试项目投标

Bidding for the E26&E27 Consulting and Testing Project on Ship Cybersecurity

联合体单位一与联合体单位二自愿组成联合体，共同参与船舶网络安全 IACS UR E26&E27 咨询、测试（以下简称“本项目”）的投标工作。  
Consortium Member One and Consortium Member Two voluntarily form a consortium to jointly participate in the bidding work of IACS UR E26&E27 consultation and testing for Ship Cybersecurity (hereinafter referred to as "this project").

联合体名称：ASI - 挪华威(DNV) 船舶网络安全E26&E27咨询及测试联合体。  
Consortium Name: ASI - DNV Ship Cybersecurity E26&E27 Consulting and Testing Consortium.

联合体牵头方为：  
The leading party of the consortium is:  
中控海洋装备（新加坡）有限公司  
AquaSync Innovation (Singapore) Pte. Ltd

本协议适用于接受联合体投标的船舶及海工项目，此协议对工作期限及工作范围做出如下规定：  
This agreement is applicable to ship and offshore engineering projects that accept joint bids. This agreement stipulates the working period and scope as follows:

- 合作期限及退出  
Term of cooperation and withdrawal  
(1) 本协议自签定之日起一年内有效；  
This agreement shall be valid for one year from the date of signing.  
(2) 到期后由双方共同决定是否续签联合体协议；  
After expiration, both parties shall jointly decide whether to renew the consortium agreement.  
(3) 在协议期内，任一方可提出退出该协议，经双方共同确定后本协议可解除；  
During the term of the agreement, either party may propose to withdraw from the agreement. This agreement may be terminated upon mutual confirmation by both parties.  
(4) 在协议期内，任何一方如违反本协议及附件中所规定内容，经另一方书面要求限期整改后仍不符合约定的，本协议可立即解除。  
During the term of this agreement, if either party violates the contents stipulated in this agreement and its annexes and still fails to comply with the agreement after being requested in writing by the other party to rectify within a specified period, this agreement may be immediately terminated.
- 联合体单位一（ASI）负责的主要工作内容：  
The main tasks of Consortium Member One (ASI) are as follows:  
(1) 客户市场推广；  
Customer marketing promotion

- 提供测试工程师及测试设备并执行测试工作。  
Provide test engineers and test equipment and carry out test work.
- 联合体单位二（挪华威 DNV）负责的主要工作内容：  
The main tasks of the member two of the consortium (DNV) are as follows:  
(1) 提供技术咨询，提供技术方案和测试大纲；  
Provide technical consultation, technical solutions and test Outlines;  
(2) 对测试工程师进行培训；  
Train test engineers;  
(3) 对现场测试进行见证，并核准测试报告。  
Witness the on-site tests and approve the test reports.

4、双方在公正和独立的情况下共同承担工作内容：  
Both parties shall jointly undertake the work content in a fair and independent manner:  
(1) 以联合体形式对外市场推广和承接订单；  
Promote the external market and undertake orders in the form of a consortium;  
(2) 对技术方案、测试大纲、测试报告共同确认。  
Jointly confirm the technical solution, test outline and test report.

5、项目投标确认  
Project bid confirmation  
(1) 项目投标时需确认联合体投标意愿，共同确认后本协议生效。  
When bidding for the project, the willingness of the consortium to bid must be confirmed. This agreement shall come into effect after joint confirmation.  
(2) 双方就具体项目需签署附录B中的《投标项目确认书》。  
Both parties are required to sign the "Confirmation of Bidding Project" on Appendix B for the specific project.

此协议附加条款见附录A  
The additional terms of this agreement can be found on Appendix A

联合体单位一： Consortium Member One 中控海洋装备（新加坡）有限公司 AquaSync Innovation (Singapore) Pte. Ltd PAYA LEBAR ROAD #07-54 PAYA LEBAR SQUARE SINGAPORE (409051)	联合体单位二： Consortium Member Two 上海挪华威认证有限公司 DNV Business Assurance (China) Co., Ltd. 中国上海市长宁区虹桥路1591号9号楼A座 Site A, House 9, 1591 Hongqiao Road, Changning, Shanghai, China
沈丽莉 Shen Li Li 管理代表 On Behalf	康文煜 Kang Wen Yu 管理代表 On Behalf

本协议自双方签署之日起生效  
This agreement shall come into effect as of the date when both parties sign and affix their seals  
终止条件：双方共同书面同意终止  
Termination condition: Both parties mutually agree in writing to terminate

签署地点及日期：  
Place and Date  
上海, 2025年8月5日  
5 August 2025, Shanghai

# Corresponding Qualifications for Ship Cybersecurity E26



On April 02, 2024, DNV, a professional risk management service agency, has issued certificates of ISO 9001:2015 quality management system, ISO/IEC 27001:2022 Information security management system and ISO/IEC 20000:2018 Information technology service management system to AquaSync Innovation.

«« DNV  
GB/T 19001-2016/ISO 9001:2015

Quality Management System

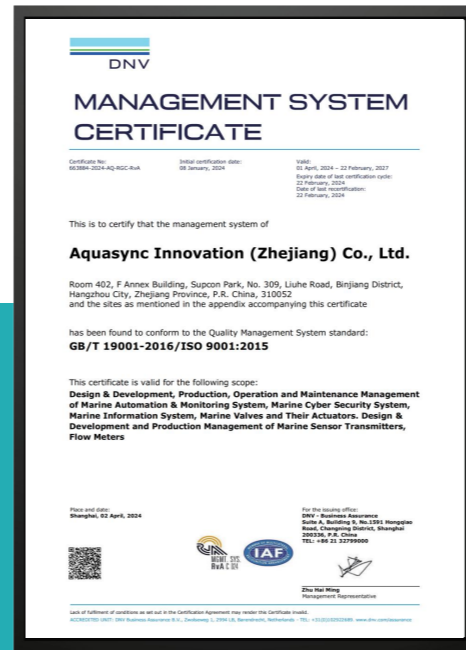

«« DNV  
ISO/IEC 27001:2022

Information Security, Cybersecurity and Privacy Protection Information Security Management Systems Requirements



«« DNV  
ISO/IEC 20000-1:2018

Information Technology-service Management Part 1:Service Management System Requirements



«« DNV  
IEC 62443 4-1 & 2-4

Security for Industrial Automation and Control Systems



# IEC 62443 4-2



- Marine Defender System
- Network Security Detection System
- Marine Network Firewall
- Cybersecurity Management Platform

**CERTIFICATE**

Certificate No.: IPA-CS-10488181-2025JA01

Initial certification date: 2025-01-10

Valid Until: 2030-01-09

**Certificate Holder:** AQUASYNC INNOVATION (SINGAPORE) PTE LTD.

**Location:** (1): 60, PAYA LEBAR ROAD, #07-54 (409051), PAYA LEBAR SINGAPORE  
(2): Room1808, Pingan Fortune Center, Binhu District, Wuxi, Jiangsu, CHINA

**Codes and Standards:** IEC 62443-4-2:2019

**Certificate Coverage (including Version):** Product: Marine Defender System  
Model: SO-MDS01  
Version: V2.20.00.00

**Security Level Achieved:** Security Level 2

**Requirements Assessed:** FR 1 - Identification and Authentication Control (AC): 13/14  
FR 2 - Use Control (UC): 11/13  
FR 3 - System Integrity (SI): 12/14  
FR 4 - Data Confidentiality (DC): 3/5  
FR 5 - Restricted Data Flow (RDF): 3/5  
FR 6 - Timely Response to Events (TRE): 2/2  
FR 7 - Resource Availability (RA): 8/8

**Validity:** This certificate is valid until 2030-01-09.

This certificate of conformity is based on an assessment conducted by DNV, the results of which are documented in Report No. Rep-IPA-CS-10488181-2025JA01, dated 2025-01-06. The process capability for this product has been previously assessed for compliance with the IEC 62443-4-1 standard, as detailed in Report Reference No. Rep-IPA-CS-10488181-2024DE01.

This certification applies only to the products specified within the coverage statement, including names, models, and version.

**Place and date:** Shanghai, China 2025-01-10

**Vincent Zhao Ph.D.**  
Head of Transportation & Cybersecurity Assurance

**Li Xiang**  
Product Assurance & Inspection Service Director of Greater China

DNV BUSINESS ASSURANCE CHINA Co. LTD, House No.9, 1591 Hong Qiao Road, Shanghai 200336, P. R. China. Tel: 86 (0) 21 3278 9000 Fax: 86 (0) 21 6278 8090

**CERTIFICATE**

Certificate No.: IPA-CS-10488181-2025JA01

Initial certification date: 2024-12-12

Valid Until: 2029-12-11

**Certificate Holder:** AQUASYNC INNOVATION (SINGAPORE) PTE LTD.

**Location:** (1): 60, PAYA LEBAR ROAD, #07-54 (409051), PAYA LEBAR SINGAPORE  
(2): Room1808, Pingan Fortune Center, Binhu District, Wuxi, Jiangsu, CHINA

**Codes and Standards:** IEC 62443-4-2:2019

**Certificate Coverage (including Version):** Product: Marine Network Firewall  
Model: SO-MFW100M  
Version: SO-MFW V4.0

**Security Level Achieved:** Security Level 2

**Requirements Assessed:** FR 1 - Identification and Authentication Control (AC): 12/14  
FR 2 - Use Control (UC): 9/13  
FR 3 - System Integrity (SI): 12/14  
FR 4 - Data Confidentiality (DC): 3/5  
FR 5 - Restricted Data Flow (RDF): 3/5  
FR 6 - Timely Response to Events (TRE): 2/2  
FR 7 - Resource Availability (RA): 8/8

**Validity:** This certificate is valid until 2029-12-11.

This is based on an assessment conducted by DNV, the results of which are documented in Report No. Rep-IPA-CS-10488181-2025JA01, dated 2024-12-08. The process capability for this product has been previously assessed for compliance with the IEC 62443-4-1 standard, as detailed in Report Reference No. Rep-IPA-CS-10488181-2024DE01.

This certification applies only to the products specified within the coverage statement, including names, models, and version.

**Place and date:** Shanghai, China 2025-01-10

**Vincent Zhao Ph.D.**  
Head of Transportation & Cybersecurity Assurance

**Li Xiang**  
Product Assurance & Inspection Service Director of Greater China

CHINA Co. LTD, House No.9, 1591 Hong Qiao Road, Shanghai 200336, P. R. China. Tel: 21 6278 8090

**CERTIFICATE**

Certificate No.: IPA-CS-10488181-2025JA01

Initial certification date: 2025-03-03

Valid Until: 2030-03-02

**Certificate Holder:** AQUASYNC INNOVATION (SINGAPORE) PTE LTD.

**Location:** (1): 60, PAYA LEBAR ROAD, #07-54 (409051), PAYA LEBAR SINGAPORE  
(2): Room1808, Pingan Fortune Center, Binhu District, Wuxi, Jiangsu, CHINA

**Codes and Standards:** IEC 62443-4-2:2019

**Certificate Coverage (including Version):** Product: Network Security Management Platform  
Model: SO-NSMP01  
Version: V3.0

**Security Level Achieved:** Security Level 2

**Requirements Assessed:** FR 1 - Identification and Authentication Control (AC): 13/16  
FR 2 - Use Control (UC): 9/23  
FR 3 - System Integrity (SI): 17/35  
FR 4 - Data Confidentiality (DC): 3/3  
FR 5 - Restricted Data Flow (RDF): 4/4  
FR 6 - Timely Response to Events (TRE): 2/2  
FR 7 - Resource Availability (RA): 9/9

**Validity:** This certificate is valid until 2030-03-02.

This is based on an assessment conducted by DNV, the results of which are documented in Report No. Rep-IPA-CS-10488181-2025MA02, dated 2025-02-28. The process capability for this product has been previously assessed for compliance with the IEC 62443-4-1 standard, as detailed in Report Reference No. Rep-IPA-CS-10488181-2024DE01.

This certification applies only to the products specified within the coverage statement, including names, models, and version.

**Place and date:** Shanghai, China 2025-03-03

**Vincent Zhao Ph.D.**  
Technical Director of Transportation & Cybersecurity Assurance

**Li Xiang**  
Product Assurance & Inspection Service Director of Greater China

CHINA Co. LTD, House No.9, 1591 Hong Qiao Road, Shanghai 200336, P. R. China. Tel: 21 6278 8090

**CERTIFICATE**

Certificate No.: IPA-CS-10488181-2025JA01

Initial certification date: 2025-02-28

Valid Until: 2030-02-27

**Certificate Holder:** AQUASYNC INNOVATION (SINGAPORE) PTE LTD.

**Location:** (1): 60, PAYA LEBAR ROAD, #07-54 (409051), PAYA LEBAR SINGAPORE  
(2): Room1808, Pingan Fortune Center, Binhu District, Wuxi, Jiangsu, CHINA

**Codes and Standards:** IEC 62443-4-2:2019

**Certificate Coverage (including Version):** Product: Network Security Detection System  
Model: SO-NSDS01  
Version: V4.0

**Security Level Achieved:** Security Level 2

**Requirements Assessed:** FR 1 - Identification and Authentication Control (AC): 13/16  
FR 2 - Use Control (UC): 9/23  
FR 3 - System Integrity (SI): 17/35  
FR 4 - Data Confidentiality (DC): 3/3  
FR 5 - Restricted Data Flow (RDF): 4/4  
FR 6 - Timely Response to Events (TRE): 2/2  
FR 7 - Resource Availability (RA): 9/9

**Validity:** This certificate is valid until 2030-02-27.

This is based on an assessment conducted by DNV, the results of which are documented in Report No. Rep-IPA-CS-10488181-2025MR01, dated 2025-02-26. The process capability for this product has been previously assessed for compliance with the IEC 62443-4-1 standard, as detailed in Report Reference No. Rep-IPA-CS-10488181-2024DE01.

This certification applies only to the products specified within the coverage statement, including names, models, and version.

**Place and date:** Shanghai, China 2025-02-28

**Vincent Zhao Ph.D.**  
Technical Director of Transportation & Cybersecurity Assurance

**Li Xiang**  
Product Assurance & Inspection Service Director of Greater China

CHINA Co. LTD, House No.9, 1591 Hong Qiao Road, Shanghai 200336, P. R. China. Tel: 21 6278 8090

# CCS Certification

**中国船级社**  
CHINA CLASSIFICATION SOCIETY

证书编号/Certificate No.: ZG23PT000184

**型式认可证书**  
CERTIFICATE OF TYPE APPROVAL

兹证明本证书所述制造商具备按照下列标准的要求生产本证书所列产品的能力和条件。  
This is to certify that the manufacturer stated in the certificate meets the requirements of the standards listed below and is available with the ability and conditions to produce the products described on the certificate.

**制造商/Manufacturer:** 中控海洋装备(浙江)有限公司  
Supcon Ocean Technology (Zhejiang) Co., Ltd

**地址/Address:** 中国浙江省杭州市萧山区东洲街道高尔山路209号第4幢308室, 邮编: 311401  
Room 308, Building 4, No.209 Gaerlu Road, Dongzhou Subdistrict, Fuyang District, Hangzhou City, Zhejiang Province, postal code: 311401

**产品名称/Product:** 船舶网络防火墙  
Marine Network Firewall  
船舶网络安全设备  
Marine Network Security Device

**附加标志/Notations:** 无/Nil.

**认可标准/Approval Standard:** 1. 中国船级社《钢质海船入级规范》(2023)及其变更通报第7章第2章 Chapter 2, Part Seven, China Classification Society Rules for Classification of Sea-going Steel Ships 2023 and its Change Notices  
2. 中国船级社《船舶网络防火墙检验指南》(2023) China Classification Society Guidelines for Inspection of Ship Network Firewall  
3. IACS UR E27《船舶系统和设备网络安全》 IACS UR E27 Cyber Resilience of On-board Systems and Equipment

**用于/Intended for:** 船舶/Ships

**产品说明/Product Description:** 船舶网络安全设备 (Marine Network Security Device (30001))

名称/Name	属性(值)/Value	单位/Unit
船舶网络防火墙	船舶网络安全设备	

本证书的有效性依赖于制造商符合本证书中规定的条件。如有变更，制造商应通知本证书的有效性。  
The certificate is valid provided the manufacturer complies with the conditions specified in the certificate. Any change shall be notified to the certificate holder.

本证书的有效性依赖于制造商符合本证书中规定的条件。如有变更，制造商应通知本证书的有效性。  
The certificate is valid provided the manufacturer complies with the conditions specified in the certificate. Any change shall be notified to the certificate holder.

发证日期: 2023年09月19日  
Date: Sep. 19, 2023

第1页/共3页/ Page 1 of 3



The Marine Network Firewall we provide has obtained the first CCS Domestic Type Approval Certificate for Cybersecurity equipment.

# Laboratory Certificate



## Laboratory Capabilities DNV ISO/IEC 17025 Certification

Baseline Verification

Vulnerability Scanning

Penetration Testing

E27 & E26  
Compliance Testing

## ISO/IEC 17025:2017

Marine Cybersecurity Product Testing, Marine Computer Based System (CBS) Cybersecurity Testing, Ship Cybersecurity Testing



## STATEMENT OF CONFORMITY

Statement No.: SCPA-GC-LAB-794970 Rev.00 Initial date: March 01, 2025 Validity: Feb.29, 2028

This statement consists of <12 > pages

We hereby declare that the quality management system of:  
**AQUASYNC INNOVATION (SINGAPORE) PTE. LTD.**  
**Marine Cyber Security Laboratory**

Service Address: Room 1808, Ping An Wealth Center, Binhu District Wuxi, Jiangsu, China 201201

Registered Address: 60, PAYA LEBAR ROAD, #07-54(409051), PAYA LEBAR, Singapore  
Has found to comply with the requirements of DNV Laboratory Quality Management System towards subcontractor of

**Marine cyber security product testing, Marine Computer Based System (CBS) cyber security testing, Ship cyber security testing**

The acceptance is based on requirements of the  
**DNV Laboratory Quality Management System with reference to ISO/IEC 17025:2017**

Further details are given overleaf

Place and date:  
Shanghai, Feb. 28, 2025

For the issuing office:  
DNV SCPA China

李向  
LI Xiang  
Director of IPA  
DNV SCPA China



Lack of fulfillment of conditions as set out in the assessment agreement may render this statement invalid.  
Issuing office: DNV SCPA China, House No.9, 1591 Hong Qiao Road, Shanghai 200336, P. R. China. Tel: 86(0)21 3279 9000 Fax: 86(0) 21 6278 8090  
[www.dnv.com](http://www.dnv.com)

Page 1 of 12

# Statistics on Ships Supported for Cybersecurity Certification – E26

Statistical time: November 20, 2025

NO.	Ship Type	ABS	LR	CCS	DNV	BV	RINA	Total
1	Container	3	16	22	20	14	3	78
2	Oil Chemical Tanker	36	34	8	10	6	6	100
3	Platform Supply Vessel	7		5	3	5		20
4	Cable-Laying Vessel		1	1				2
5	AHT	14				2		16
6	Deck Carrier		2	1	2			5
7	Bulk Carrier	6	4	8	5	4	2	29
8	Refrigerated Transport Vessel		1	6				7
9	Offshore Operation Vessel	2			4	2		8
<b>Total</b>		<b>68</b>	<b>58</b>	<b>51</b>	<b>44</b>	<b>33</b>	<b>11</b>	<b>265</b>

# Our Service Capabilities – Personnel Qualifications

